

# SIRUBA®

銀箭牌工業用縫紉機

INDUSTRIAL SEWING MACHINE

# DL918-BM1/BH1

## 使用說明書 INSTRUCTION BOOK



CE

 高林股份有限公司  
KAULIN MFG. CO., LTD.



# EC DECLARATION OF CONFORMITY

According to the following European Directive  
Machinery Directives:98/37/EC(MD), 2006/95/EC(LVD).

The undersigned, ROBERT TSAI, representing KAULIN MACHINERY AND ELECTRONIC INDUSTRIAL (NONGBO) CO., LTD. No. 16 Longtanshan Rd. Daqi Tw, Beilun District, Ningbo City, Zhejiang Province, P. R. China, manufacturer, Declares that the machine described hereafter:

Lockstitch Sewing Machine.

Model:DL918

Provided that it is used and maintained in accordance with the generally accepted codes of good practice and the recommendations of the instructions manual, meets the essential safety and health requirements of the Machinery Directive.

For the most specific risks of the machine, safety and compliance with the essential requirements of the Directive has been based on elements of : the European Standard EN ISO 10821:2005, EN 60204-1:2006 Safety of machinery; basic concepts, general principles for design.

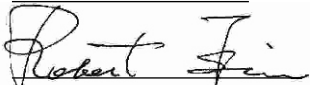

The compliance of the model with the requirements of EC Machinery Directive was established by AIB-VINCOTTE Inter n.f.p. Avenue A. Drouart 27-29, B 1160, Brussels, Belgium (Notified body under the number 26 for machinery listed in annex IV of EC Machinery Directive).

Date: Dec./11/2009





Signature: 

Qualification: R&D MANAGER

## 危險水準的說明 Explanation of Dangerous Level

 <b>危險</b> Dangerous	<p>如果忽視此標記而運行了錯誤的機械操作，保養時肯定會引起當事者或第三者人員重傷或死亡。</p> <p>Don't ignore the warning sign and don't proceed incorrect operation. Or it will cause the person or the third party seriously injured or dead during maintenance.</p>
 <b>注意</b> Caution	<p>如果忽視此標記而運行了錯誤的機械操作，保養時有可能會引起當事者或第三者人員受傷及造成設備損壞。</p> <p>Ignoring this warning sign and proceed incorrect operation will cause the person involved or the third party wounded and equipment damaged during maintenance.</p>

## 警告圖案表示及表示標誌的說明 Explanation of Warning Signs and Labels

<b>警告圖案表示</b> Warning Sign		<b>運動部位，謹防工傷事故</b> Moving part, beware of industrial accident
		<b>高壓部位，謹防觸電事故</b> High voltage, beware of electric shock
		<b>高溫部位，謹防燙傷事故</b> High temperature, beware of burns
<b>指示標誌</b> Instruction Label		<b>禁止</b> Prohibited
		<b>地線的接線表示</b> Indication of ground wiring

索引	INDEX	頁/PAGE
一般安全事項說明	GENERAL SAFETY INSTRUCTIONS	1
重要安全事項	IMPORTANT SAFETY INSTRUCTION	3
特別事項	WARNING	7
警告標籤	WARNING TAG	8
護針安全圖說	SAFETY ILLUSTRATION OF NEEDLE GUARD	9
搬運	MOVING THE SEWING MACHINE	9
關於縫紉機的安裝位置	THE INSTALLATION POSITION OF THE SEWING MACHINE	10
各部件名稱	NAMES OF MAJOR PARTS	10
規格	SPECIFICATIONS	11
關於本機的重要安全事項	IMPORTANT SAFETY INSTRUCTIONS OF THIS MACHINE	14
安裝	INSTALLATION	15
油盤安裝	OIL PAN INSTALLATION	16
針的安裝	INSTALLING THE NEEDLE	17
梭子之安裝	SETTING THE BOBBIN	17
線架安裝	THREAD STAND ASSEMBLY	18
機頭穿線	THREADING THE MACHINE	19
針距調整	STITCH LENGTH ADJUSTMENT	19
膝控壓具提升器之調整	ADJUSTMENT OF THE KNEE CONTROLLER FOR HIGHER PRESSER FOOT LIFTING	20
針線/梭線鬆緊度調整	NEEDLE THREAD/BOBBIN THREAD TENSION ADJUSTMENT	20
控線組彈簧調整	THE THREAD TAKE-UP SPRING ADJUSTMENT	21
壓具提升桿	MANUAL FOOT LIFTER LEVER	22
壓具壓力調整	ADJUSTING PRESSER FOOT PRESSURE	22
針與送具時位調整	ADJUSTING TIMING BETWEEN NEEDLE AND FEED DOG	23
送具傾斜度	ADJUSTING THE ANGLE OF THE TILT OF THE FEED DOG	24
送具高度	ADJUSTING THE HEIGHT OF THE FEED DOG	25
針與梭頭時位關係	CORRELATION BETWEEN NEEDLE AND HOOK	26

壓具高度調整	PRESSER FOOT HEIGHT ADJUSTMENT	27
導線片之調整	THE THREAD TAKE-UP STROKE ADJUSTMENT	28
腳踏板壓力及行程	ADJUSTING THE TENSION ON PEDAL AND	28
腳踏板調整	ADJUSTING THE PEDAL	29
撥線桿調整	ADJUSTING THE THREAD WIPER	30
梭頭油量調整	ADJUSTING THE AMOUNT OF OIL IN THE HOOK	31
操作環境照明	LIGHTING OF THE OPERATION ENVIRONMENT	32
操作者條件	CONDITIONS OF ALL OPERATORS	33
腳踏板之操作	OPERATING THE PEDAL	33
單觸式倒縫機構	OPERATING THE ONE TOUCH TYPE REVERSE FEED STITCHING MECHANISM	34
保養	MAINTENANCE	35
潤滑	LUBRICATION	37
動刀與固定刀的更換	REPLACE THE MOVABLE KNIFE AND FIXED KNIFE	39
桌板圖	TABLE CUT-OUT	42
報廢流程	DEMOLITION PROCEDURE	43

### **警告！**

當使用這台機器，基本安全預防應恆被遵守，以減輕火災、電擊、或是個人傷害的風險。包含以下注意事項。

在操作這台機器之前，請閱讀所有說明並且緊記於心。

#### **1. 保持工作場所清潔**

雜亂的環境與椅子會招引危害。

#### **2. 考量工作場所環境**

物暴露電源於雨水之中、勿在濕氣重的地方或潮濕的場所使用機械器具。保持工作場所良好整齊。當有引發火災或爆炸危險時，勿使用電源工具。

#### **3. 免於電擊危害**

避免身體接觸地線或是接地表面。（即：管線，發熱物體，以及冷凍庫）

#### **4. 勿使孩童接近**

不要讓訪客碰觸工具或是延伸管線

#### **5. 適當的穿著**

不要穿著寬鬆衣物或是穿戴珠寶，這可能被活動零件拉扯而導致危險。穿戴護髮套以包含住長髮。

#### **6. 不要任意拉扯電線**

絕不要用電源端拉扯機器，或是從插座猛拉電線來拔掉電線。使電線遠離熱源、油類或是尖銳邊緣。

#### **7. 謹慎保養機器**

遵從指示來添加潤滑油或是更換附件。定期檢測工具用線，如果有所損害，請使用合格的維修器具來修復。

### **Warning!**

When using this machine, basic safety Precautions should always be followed to reduce the risk of fire, electric shock and personal injury, including the followings. Read all these instructions before operating this product and save these instructions.

#### **1. Keep work area clean**

Cluttered areas and benches invite injuries.

#### **2. Consider work area environment**

Do not expose power to rain. Do not use machine tools in damp or wet locations. Keep work area well lit.

Do not use power tools where there is risk to cause any fire or explosion.

#### **3. Guard against electric shock**

Avoid body contact with earthed or grounded surfaces (e.g. Pipes, radiators, ranges refrigerators.)

#### **4. Keep children away**

Do not let visitors touch the tool or extension code.

#### **5. Dress properly**

Do not wear loose clothing or jewelry, they can be caught in moving parts. Wear protecting hair covering to contain long hair.

#### **6. Do not abuse the cord**

Never carry the machine by cord or yank it to disconnect it from the socket. Keep the cord away from heat, oil, and sharp edges..

#### **7. Maintain machine with care**

Follow instructions for lubrication and changing accessories. Inspect tool cord periodically. If damaged, have it repaired by an authorized service facility.

8. **中斷機器電源**  
當不使用機器時、維修前、以及更換配件時。
9. **避免誤啓動**  
不要以手指置於啓動開關上之後，搬運一個已插入電源的工​​具。確定在插電之前，電源開關是關閉的。
10. **檢查損害零件**  
在進一步使用器具之前，應該小心檢查並確認損傷的零件或是穿戴保護器具來確認零件會正確運轉並且呈現應有功能。
11. **警告**  
除了在這本使用說明手冊中建議的功能之外，任何附件或是配件的使用，都可能會導致個人傷害的危險。
12. **由合格人員來修理事具**  
所以修理工作應由合格的人員使用原始個別零件來作修理。

## **連接電源的特別警示**

1. 只可與有 "CE" 認證的按壓啓動裝置連接這台機器。
2. 遵守此使用說明手冊來安裝控制裝置。
3. 在操作過程中，永遠保持機器適當的接地。
4. 再調整、更換零件、或是維修保養之前，必須確定將插頭由插座拔出，以預防任何機器意料之外的啓動而造成危害。

8. **Disconnect machine**  
When not in use, before servicing and when changing accessories.
9. **Avoid unintentional starting**  
Do not carry a plug-in tool with a finger on the switch. Ensure the power switch is off when plugging in.
10. **Check damaged parts**  
Before further use of the tool, a guard or other part that is damaged should be carefully checked to determine that it will operate properly and perform its intended function.
11. **Warning**  
The use of any accessory or attachment, other than those recommended in this instruction manual, may present a risk of personal injury.
12. **Have your tool repaired by a qualified person**  
Repairs should only be carried out by qualified persons using original spare parts.







## **SPECIAL WARNING FOR ELECTRIC CONNECTION!**







1. Incorporate this machine only with "CE" certificate hold-to-run control device.
2. Follow the instruction manual device to install control device.
3. Always earth machine appropriately during operation.
4. Before adjustment, parts change or servicing must be sure to pull out the plug from socket to prevent the hazard of unintentionally start of machine.





恭喜您購買本機器，為了使這台機器能獲得最佳功能以及安全的操作，務必請正確的使用這台機器，使用前請仔細閱讀使用說明書，希望您能長期使用它。請記得將此說明書放在容易取得的地方。

For operating safely and getting the best functions of this machine, you must operate it correctly. Please read and follow the instructions of this manual, and keep it at hand for future references. We are confident that you will enjoy this machine as much as we enjoy manufacturing it.

-  1. 當您使用機器時，除了以下事項外，請注意其他基本安全措施。
-  2. 使用機器前，除了這本使用說明書外，請詳細閱讀其他相關說明書。此外，請妥善保存此說明書，以便需要時可以隨時取閱。
-  3. 先確認機器是符合貴國安全規定及標準後，再使用機器。
-  4. 當機器完成操作準備時，所有安全配備必須安裝就緒，在缺少所述安全配備下操作是不被允許的，以免導致人員受傷。
-  5. 此機器應由受過適當訓練之操作員操作。
-  6. 為了安全，我們建議您配戴安全眼鏡。
-  7. 以下情形，請先關閉電源或拔掉插頭：
  - (1) 穿針線、導線片、天平等以及更換梭子時。
  - (2) 更換針、壓具、針板、送具、頂針片、喇叭、車布導板，以及其他附屬配件時。

-  1. Instead of the following instructions, when you use this machine, please pay attention to the basic safety measures.
-  2. Before using this machine, please read this manual and all related instructions. In addition, please keep this manual for future needs.
-  3. Before using this machine, please ascertain that it conforms with safety standards and regulations of your country.
-  4. When the machine is ready for operation, all the safety equipments must be ready. Operate this machine without the specified safety devices is not allowed.
-  5. This machine must be operated by a properly trained operator.
-  6. For your own safety, we suggest you wearing goggles.
-  7. Please turn off the power switch or disconnect it for any one of the circumstances of the followings:
  - (1) When threading needle(s), adjusting thread Take-up(s), thread guide(s), and/or replacing bobbin(s).
  - (2) When replacing needles, presser feet, needle plates, feed dogs, needle guards, horns, cloth guides and other parts or accessories.

- (3) 維修工作時。
- (4) 離開工作場所或工作場所無人看顧時。
- (5) 若使用離合器馬達而無煞車片裝置時，必須待馬達完全停止。

 8. 假如不慎讓機器及配件使用之油或油脂，接觸到眼睛、皮膚或誤食時，請立刻以水清洗接觸部位及就診。  

 9. 請勿擅自碰觸運轉中之零件及配件及注意機器電源是否已開啓，以免導致人員受傷。

 10. 維修、修改及調整等工作，須由受過適當訓練的技師或熟手為之。維修時只許使用指定之零件。

 11. 一般維修及檢查工作必須由受過適當訓練的人員為之。

 12. 電子零件維修及保養工作必須由資深的電子技師為之，或由非常熟練的人員檢查及指導，當發現零件損壞時，請立刻停止機器運轉。

 13. 在做裝有氣動式零件（例如氣缸）機器的維修及保養工作前，機器連接空壓機及高壓空氣必須予以關閉及卸除，機器中殘存高壓氣體必須予以消除，此外調整及性能檢查只能由受過適當訓練的技師或熟手為之。

- (3) When repairing.
- (4) When the operator leaves the working place or leaves the machine unattended.
- (5) If clutch motors without brake pads are used, must wait until the motor stops completely.

 8. If grease, oil, or any fluid contacts your skin or eyes by any chance, please wash the contacted area completely with clean water and consult a doctor. Or, swallow any fluid mistakenly, consult a doctor immediately.

 9. Do not touch any functioning parts and devices. Always attend to whether power switch is on or off before operating in order to prevent anyone from getting hurts.

 10. Qualified technicians are required for adjustment, modification, and repair. Only use assigned parts for replacement.

 11. Routine maintenance and service must be performed by well trained persons, or qualified technicians.

 12. Maintain and check the electronic parts must be done by qualified electrician or well-trained persons. If any electronic part damaged or malfunctioned, stop the machine immediately.

 13. The air house has to be detached from the machine and the compressor or air supply has to be cut off before repairing and servicing the machine equipped with pneumatic parts such as an air cylinder. Qualified technicians or well-trained persons are required for adjustment and repairs.

 14. 機器使用一段時間，必須定期清理。

 15. 為使機器能正常操作以及減少噪音，機台務必平放地上，機器避免在強烈噪音的環境下操作。

 16. 選用適當的電源插頭，並由電子技師將其安裝在機器上，且插頭必須插在接地線之插座上。

 17. 機器只允許被使用於指定用途上，其他用途是不允許的。

 18. 修改或變更機器必須依照安全規定及標準，同時採取有效的安全措施或變更機器所引起損壞之責。

19. 警告提示以兩種符號標示：



(1) 對操作員或服務人員之傷害危險，也為了避免觸電之危險，請勿打開馬達電器箱之外蓋，也不要觸摸電器箱裡面之零件。



(2) 必須特別注意事項  
a. 絕對不可在移動皮帶蓋，手指保護蓋或安全配件後，進行機器操作，以免導致人員受傷。



14. To ensure the best performance, periodically clean the machine is necessary.



15. In order to operate properly and to reduce the noise, please place the machine flat and level on the ground. Avoid operating the sewing machine at a noisy surrounding.



16. Select a proper power plug and install it by an electrician. Please connect the power plug to a grounded receptacle.



17. This machine can only be used for the designed purpose. Other uses of this machine are not allowed.



18. Any modification or conversion made on this machine must be conformed with the safety standards and regulations. Precaution is necessary. No responsibility will our company take for damages caused by any modification or conversion of this machine without permission.

19. Two safety warning signs are applied as warning signs:



(1) For the safety of operators and service persons, please don't open the cover of any electronic control boxes of motor or other devices and don't touch any components inside to avoid electrical shock hazards.



(2) Always keep in mind:  
a. Please never operate this machine without belt cover, finger guard or any safety device to avoid physical injury.



b. 為了避免被機器纏住，當機器運轉中，您的手、頭髮及衣服，需遠離手輪，皮帶及馬達；此外這些部位周圍不可放置任何物品，以免導致人員受傷。



b. Please keep your hair, fingers and clothes away from the hand wheel, V belt and motor while the machine is in operation, as well as never put anything near these parts, to prevent the risk of injuries by tangled into them.



c. 當您打開電源開關後或機器已在運轉中，絕不可將您的手放在針的下方或針線控線桿外蓋中，以免導致人員受傷。



c. Please never put your fingers under the needle(s) or in the thread take-up cover to prevent physical injuries when you turn on the power switch or operate the machine.



d. 當機器運轉中，梭頭高速轉動，為了避免對手可能引起之傷害，必須確定您的手保持遠離梭頭附近。此外，當更換梭子時，確定電源開關已關閉，以免導致人員受傷。



d. While the machine is in operation, the hook rotates at a high speed. Please keep your hands away from the area of hook to prevent any potential injury to your hands. In addition, please make sure to turn off the power of the machine while changing bobbins.



e. 當放置或抬起機器時，小心勿將手置於機器中，以免導致人員受傷。



e. Be careful and do not place your fingers inside the machine when placing or lifting the machine head to avoid possible physical injuries.



f. 為了避免機器突然啓動而引起可能意外，當機頭傾斜或移開皮帶蓋及皮帶時，請關掉機器電源，以免導致人員受傷。



f. Please turn off the power before tilting the machine head or removing the belt cover and the V belt to avoid possible accidents due to abrupt start of this machine.



g. 如果您的機器是配置伺服馬達，機器於靜止狀態時，馬達是不會產生噪音的，為了避免機器突然啓動而引起可能意外，故請關掉機器電源。



g. For machine equipped servo motors, the motors do not produce noise while the machines are at rest. Therefore, please turn off the power of this machine to avoid possible accidents due to abrupt start of the machine.



h. 為了避免觸電之危險，請絕不要在移開電源接地線後操作機器。



i. 為了避免觸電或電子零件損壞而引起之可能意外，請先切斷電源，再插上或拔掉插頭。



h. Never operate the sewing machine after the ground wire is removed to avoid electrical shock hazards.



i. Please turn the power switch off before connecting or disconnecting the power plug to prevent possible accidents due to electric shock or damaged electronic components.

## 特別事項

## WARNING

為了避免機器故障及損壞，請先確定以下事項：



1. 當您安裝好機器後，做第一次機器操作前，請徹底清潔機器。



2. 清除運送途中累積之灰塵及溢出之油脂。



3. 確定電壓及馬達相數（單相或三相）安裝正確。



4. 確定電源插頭正確地接上電源。



5. 當使用電壓與標示電壓不同時，請勿使用機器。



6. 確定機器轉動方向是否正確。



警告：

在操作或調整本書中所提到之各步驟前，請先將電源關掉，以免因為機器突然啟動造成之意外。

Please confirm the followings to avoid malfunction or damage to this machine.



1. After installing the machine, and before the first operation, please clean it completely.



2. Clean all dust and overflowed oil during transportation.



3. Confirm that the voltage and the phase (single or 3 phase) of motor are set correctly.



4. Confirm that the power plug is correctly connected to the power supply.



5. Never use the machine when the local voltage type is different from the marked voltage on the nametag attached on the machine.



6. Confirm that the rotating direction of the machine pulley is correct.



Warning:

Before doing any operation or any adjustment described later in this manual, please turn the power off to prevent accidents caused by abrupt start of the sewing machine.

## 警告標籤

## WARNING TAG

- 縫紉機上有下列警告標籤。(圖1、圖2)
- 當使用縫紉機時，請遵守標籤上的說明。如果標籤脫落或模糊不清，請和購買商店聯繫。

- The following warning tags will be attached on the sewing machine. (Fig.1, Fig.2)
- When using the sewing machine, please follow the instructions of the tags. Please contact the dealer if any of the tags is fallen off or fuzzy.



圖1/ Fig. 1





圖2/ Fig. 2

③  必須接地

接駁地線不牢固，是造成觸電或誤動作的原因。

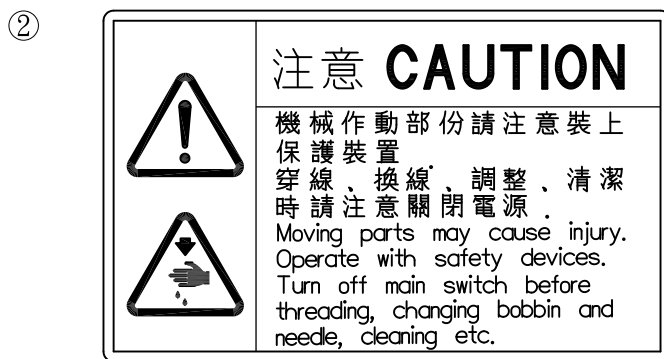
③  must have ground wire.

A loosen or a did not connect well ground wire is the reason causing electronic shock or malfunction.

④  表示轉動方向

安全保護裝置(圖3)

- (A) 護指器
- (B) 護目鏡

④  Indicates rotating direction.

Safety Protection Device (Fig. 3)

- (A) Finger protector
- (B) Goggle



圖3/ Fig. 3

## 護針安全圖說

本縫紉機之壓具防護裝置如圖所示，為保護操作者之操作安全，嚴禁將此裝置拆卸。

## SAFETY ILLUSTRATION OF NEEDLE GUARD

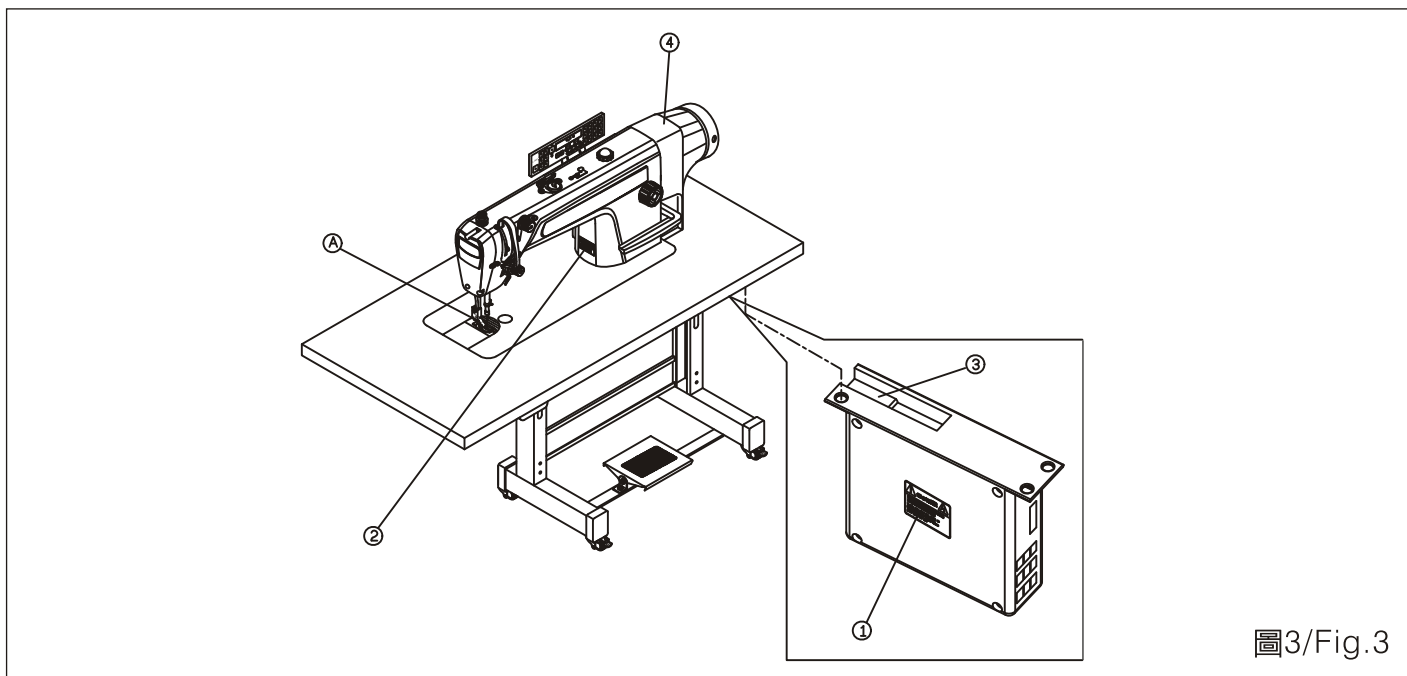
The presser foot protection device is shown as figure 3. For safety of all operators, this device is restricted to disassemble.



圖4/Fig.4

## 搬運

1. 請由兩人用手托住機殼本體進行搬運。
2. 用手扶住馬達蓋。
3. 搬運時，請穿著安全鞋。(圖5)

## MOVING THE SEWING MACHINE

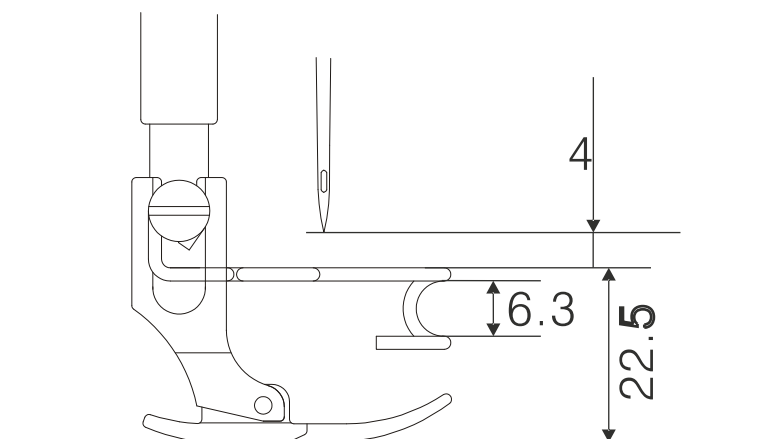
1. The machine should be carried by two people as shown in the figure.
2. Hold the motor cover firmly.
3. Please wear a pair of skidproof shoes while moving the sewing machine. (Fig.5)



圖5/Fig.5

## 關於縫紉機的安裝位置

1. 勿將縫紉機置於設備附近，如電視機、收音機或無線電話等，否則這些設備可能被縫紉機的電子干擾所影響。(圖 6)
2. 應將縫紉機直接插入 AC 電源插座，如果使用延長線，可能會造成操作故障。

## THE INSTALLATION POSITION OF THE SEWING MACHINE

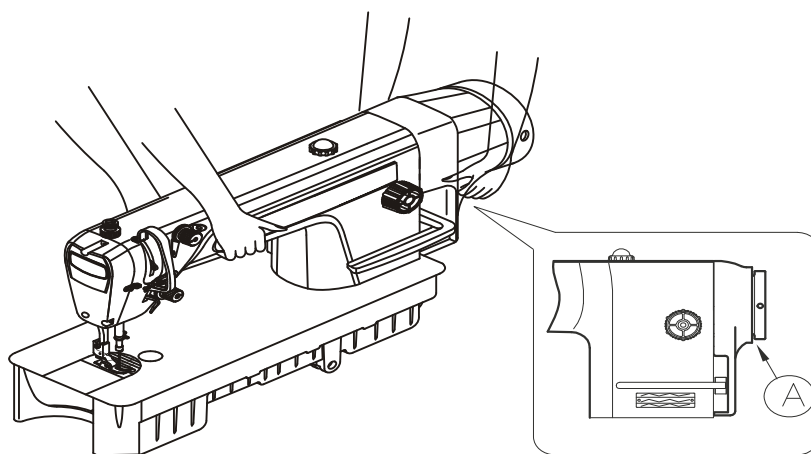
1. Please do not install the sewing machine near the equipments, such as Television, Radio, or wireless Telephone. Or these equipments will experience electronic interference. (Fig.6)
2. The wire should insert to the AC power socket directly. If using the extension wire, this might cause malfunction.

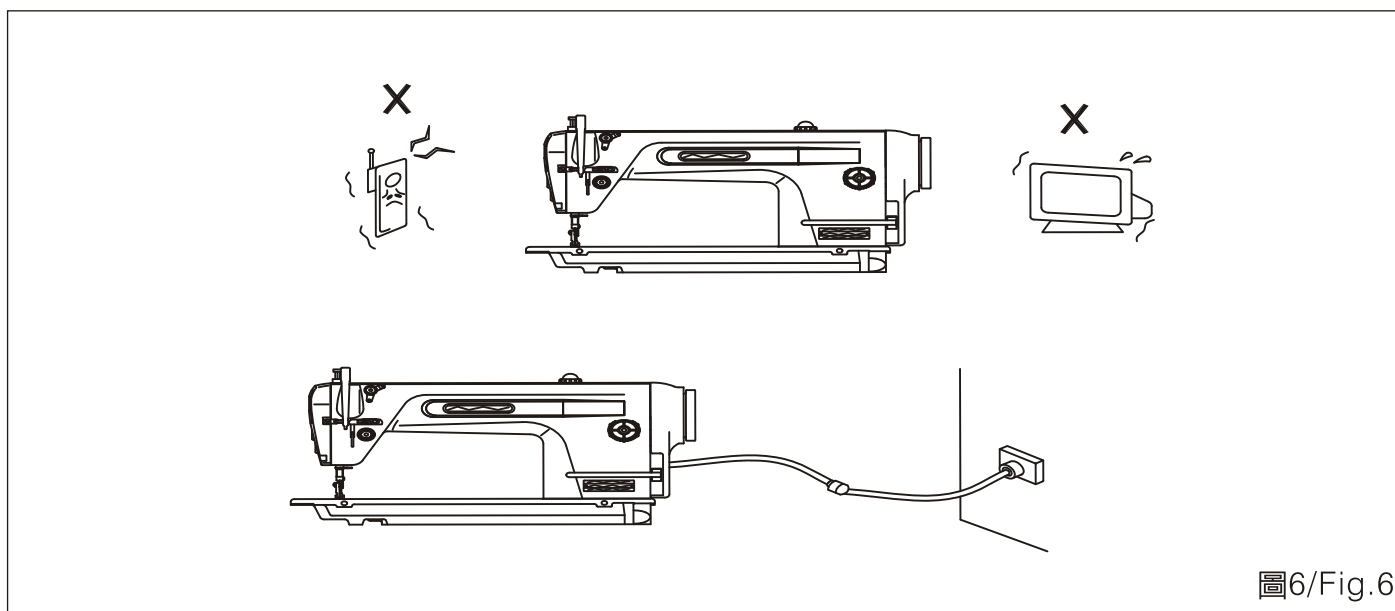

## 各部件名稱

- (1) 導線片
  - (2) 壓具
  - (3) 控制箱
  - (4) 油鏡
  - (5) 拉線鬆緊調整組
  - (6) 線架
- 安全保護裝置
- (7) 挑線桿防護罩
  - (8) 護指器

## NAMES OF MAJOR PARTS

- (1) Thread Guide
  - (2) Presser Foot
  - (3) Control Box
  - (4) Oil Windows
  - (5) Thread Tension Adjusting Set
  - (6) Thread Stand
- Safety Protection Device
- (7) Thread Take-up Cover
  - (8) Finger Guard





圖7 / Fig.7

規格

SPECIFICATIONS

種類及規格說明

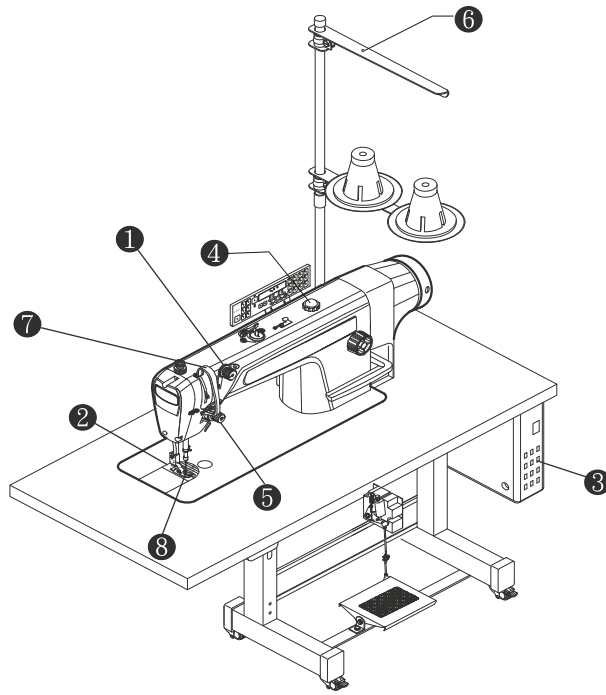
1. 型號及分類表示

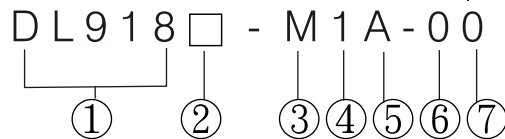

①表示機種別：  
L=高速單針下送布平縫車

②表示車台外觀改良之區分編碼，由F然後G，以英文字母排列如DL918F。

③用途項目：(表1，表2)

Specifications of machine category

1. Description of the machine name

① represents the type of the machine:  
L= High Speed One-needle Bottom Feed Lockstitch Machine

② represents the improved machine appearances that are arranged from letter F. Ex:DL918F.

③ Purposes: (Table1, Table 2)

編號 Code	用途 Application	車縫速度(r.p.m) Max Sewing Speed	縫距(mm) Max Stitch Length
M	用於中厚布料 For medium-weight materials	最高Max: 4500 一般General: 4500	0~5
H	用於中厚布料至厚布料 For medium to heavy-weight materials	最高Max: 4000 一般General: 3500	0~6

表1 / Table 1

針棒行程(mm) Needle Bar Stroke		壓具揚程(mm) Presser Foot Lift		使用針 Needle
		手動 By hand lifter	膝動 By knee lifter	
M	30.7	5.5	最大 Max: 13	DBX1 #14
H	35		一般 General: 10	DBX1 #21

表2 / Table 2

④ 梭頭代碼：

- 1：表示高速縫梭頭
- 2：表示2倍速梭頭
- 3：表示免加油梭頭
- 4：表示特殊梭頭

⑤ 無：代表針板，送具為四條齒

A：代表針板，送具為三條齒

C：代表針板，送具為三條齒，針棒及襯套選用LG04F/LG104F或LG07F/LG107F (鋁材)

⑥ 操作盒代碼：

- 0：表示SIRUBA一般型，無操作盒。
- 1：表示SIRUBA高級型，有按鍵式操作盒。

⑦ 操作盒之功能碼代碼(表3)：

④ Code of the hook:

- 1: High Speed Hook
- 2: 2-capacity Large Hook
- 3: Oil-Free Hook
- 4: Special Hook, Vertical Type

⑤ None: Four teeth rows of the needle plate and the feed dog

A: Three teeth rows of the needle plate and the feed dog

C: Three teeth rows of the needle plate and the feed dog, the needle bar and the bushing use LG04F/LG104F or LG07F/LG107F (aluminous material)

⑥ Code of operation box:

- 0: SIRUBA normal model without key type operation box
- 1: SIRUBA advanced model with key type operation box

⑦ Function code of the operation box (Table 3):

操作盒代碼及形式 Code of the operation box & its functions	功能碼 Function Code	自動切線 Automatically Thread Trimming	快速倒縫 Rapidly Backstitch	1 撥線 Thread Wiping	2 自動抬壓腳 Auto Presser Foot Lifting	操作盒 Operation Box
適用SIRUBA高級型有按鍵操作盒(1)之代碼 Suitable for SIRUBA advanced model with operation box (1)	0	○	○	-	-	L-900
	1	○	○	○	-	
	2	○	○	-	○	
	3	○	○	○	○	

表3/Table 3

2. 規格 (表 4)

2. Specification: (Table 4)











機型 Model		DL918	
車縫布料 Materials		M中厚布料- Medium-weight	H厚布料- Heavy-weight
1	車縫速度(r.p.m.) Sewing speed	Max: 4500, Normal:4000	Max: 4000, Normal:3500
2	縫距 Stitch length	0~5	0~6
3	針棒行程(mm) Needle bar stroke	30.7	35
4	使用針 Needle	DBX1 #14	DBX1 #20~23
5	壓腳壓力(kgs) Presser foot pressure	5~7	5~7
6	壓具提升量 Presser lifter	膝動Knee-drive	標準 Standard: 10mm (最大Max: 13mm) 5.5 mm
		手動Hand-drive	
7	壓具 Presser foot	可調整性壓具 Adjustable presser foot	
8	送具 Feed dog	3排齒或4排齒 3 teeth rows or 4 teeth rows	
		可調整送具斜度 Feed dog slope is adjustable	

9	送具高度(mm) Feed dog height	MIA 0.85~0.95 0.75~0.85	1.0~1.2
10	送布方式 Feeding	上下前後搖擺底送方式 Up/down and front/rear rocking bottom feeding	
11	挑線桿 Thread take-up lever	連桿方式 Connecting rod	
12	挑線桿行程(mm) Thread take-up lever stroke	59.2±1	59.5±1
13	加油方式 Lubrication	完全自動加油 Fully automatic lubricating	
14	回油方式 Oil recycle	柱塞泵方式 Pillar plug pump	
15	潤滑油 Lubricant	提供之專用油 Provided specified lubricant	
16	撥線裝置 Thread wiping device	選擇配置(Optional Device)	
17	自動回針裝置 Auto-stitch back device	標準配置(Standard Device)	
18	馬達輸送 Motor	額定輸出400W (1/2HP) 最大輸出550W (3/4HP) Regulated output: 400W(1/2HP), Max. Output: 550W (3/4 HP)	
19	使用電源 Power	3相/單相 3 Phases/single phase	
20	電磁線圈驅動電源 Electromagnetic drive power	DC-24V	
21	切線方式 Trimming type	平面咬合式 Horizontal engaged trimming type	

表4/ Table 4

3. L900電控操作盒功能說明：(表5)

3. Description of the function of L-900 operation box: (Table 5)

功能 Application	圖樣與說明 Figures & Descriptions	
起縫/縫畢選擇鍵 Start/End Tacking Selection		起縫單趟自動回針鍵 Start tacking 1 time setting
		起縫雙趟自動回針鍵 Start tacking 2 times setting
		縫畢單趟自動回針鍵 End tacking 1 time setting
		縫畢雙趟自動回針鍵 End tacking 2 times setting
車縫樣式選擇鍵 Pattern Selection		自由鍵 Free stitching setting
		定針車縫 Stitching number setting
		重複縫樣式 Overlapped stitching
		四角縫樣式 Rectangular stitching
		V型縫樣式 V type stitching
		U型縫樣式 U type stitching

功能選擇鍵 Optional Functions Selection		單觸發自動車縫鍵 One shot automatic stitching
		自動切線鍵 Automatic thread trimming
		車縫順序選擇鍵 Stitching Sequence
		提補車縫 Needle UP/DOWN

表5 / Table 5

## 關於本機的重要安全注意事項

## IMPORTANT SAFETY INSTRUCTIONS OF THIS MACHINE

### 1. 搬運作業

- (1) 使用上下二片式的保麗龍將機器包裝防護。
- (2) 放入紙箱內。
- (3) 用手推車或二人用雙手抬動搬運。

### 2. 儲存作業

- (1) 機器不使用時，應用防塵套將其罩上。
- (2) 避免儲存於高於 45 °C 以上的高溫。

### 3. 作業中

機器不要在高於 40 °C 以上的溫度工作。

### 4. 警告

請注意以下警示建議事項。

- (1) 工作區域是危險的。
- (2) 當機器還在運作的時候絕對不要去碰觸針。
- (3) 當在送布料的時候要多加小心。
- (4) 不要把手指放在針與傳送布料的轉具之間。

在貼有警告標示之處請注意。

- (1) 機械動作部分，請注意裝上保護裝置。
- (2) 穿線、換線、調整、清潔時，請注意關閉電源。

### 1. Transportation

- (1) The machine packed with two piece - up and lower - covers that made of expanded Polystyrene to protect it.
- (2) Put the machine into a carton.
- (3) Use a cart or by two men's hands to move it.

### 2. Storage

- (1) The machine must use duster cover to cover it when it did not work.
- (2) Do not storage the machine over 45 °C

### 3. Working

The machine doesn't work over 40 °C .

### 4. Warning

Pay attention to the following warning advices:

- (1) Working area is dangerous.
- (2) Never touch the needle if the machine is still running.
- (3) Be careful if you infeed fabric.
- (4) Do not insert your finger between needle and roller for transportation on fabric.

Pay attention to the warning sticker.

- (1) Movable parts must be enclosed with guard when you operate.
- (2) Turn off the power during adjusting, threading, bobbin-changing and needle-cleaning.



## 注意CAUTION



請讓受過培訓的技術人員來安裝縫紉機。  
Machine installation should only be carried out by qualified technician.



請委託購買商店電器專業人員進行電器配線。  
Contact your dealer or a qualified electrician for any electrical work that may need to be done.



縫紉機重45公斤，安裝工作必須由兩人以上來完成。  
The sewing machine weighs 45kg. The installation should be carried out by two or more people.



在安裝完成前，請不要連接電源，如果誤按啓動開關，縫紉機動作會導致受傷。  
Do not connect the power cord until installation is complete. The machine may operate if the treadle is depressed by mistake, which could result in injury.



縫紉機頭倒下豎起時，請用雙手進行操作，單手操作時可能會因縫紉機的重量過重而滑落，而導致受傷。  
Use both hands to hold the machine head when tilting it back or returning it to its original position. If only using one hand, the weight of the machine head may be too heavy to hold, and may cause human physical injuries.

1. 依本機所附桌板裁製圖及零件組合圖所列之配件，依序安裝防震機座、線架。

注意：

(1) 使用新機器，最初一個月的運轉速度約為最高轉速的 80% 請選擇正確的馬達皮帶輪尺寸。(如表 6)

(2) 桌板厚度約 40mm 。

註：皮帶尺寸會因選用馬達的形式，廠家不同而有所差異。

1. Before installing machine, please refer to table cut-out drawing, and the necessary attachment as enclosed, to fix cushion base, thread stand.

NOTE:

(1) During the first month of using the machine, the maximum speed shouldn't exceed 80% of the speed listed in Table 1. Make sure to choose the correct size of motor pulley. (Table 6)

(2) The standard thickness of Table is about 40mm.

Note: The belt size is different based on the choosing motor and brand.

## 油盤安裝

1. 油盤必須放置於桌板凹槽中之四角。(圖 8)
2. 用下圖所示之釘子②，將兩個橡皮墊①固定於 A 邊(操作員方向)，再用底質為橡膠之膠帶將兩個緩衝墊③固定於 B 邊(有鉸鍊的方向)，然後再將油盤④放上。(圖 9)

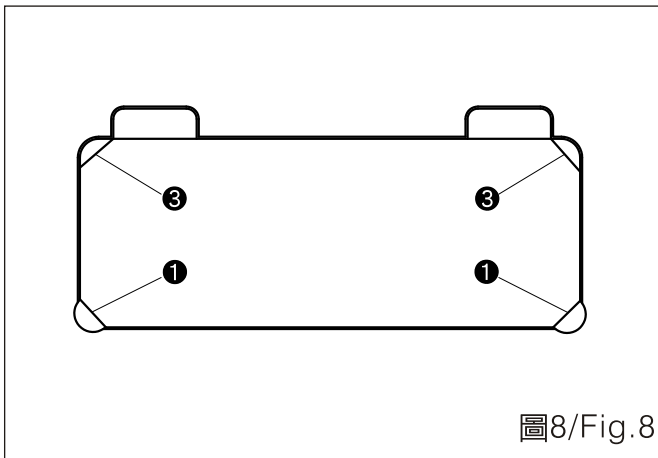

## OIL PAN INSTALLATION

1. The corners of the oil pan has to place on the four corners at the cut groove of the machine table (Fig.8)
2. Use nails ② as illustrated to fix two rubber seals ① on side A (the operator's side). Use rubber based adhesive to fix two cushion ③ seats on the living side (side B). Place oil pan ④ on the fixed seals. (Fig.9)

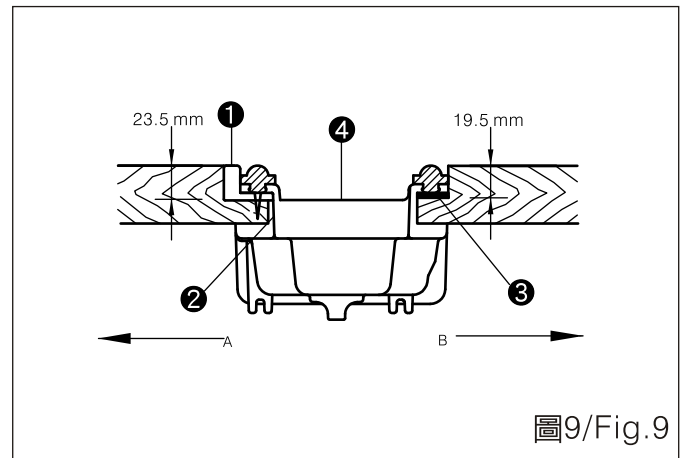

3. 在將機頭放進四個角的緩衝墊③之前，先將鉸鍊①裝進機座兩個固定孔中，再將機頭安裝於桌板相對裝有橡膠墊②之二個開口中。(圖 10、11)

3. Place the hinge ① into the two fixing holes before placing the machine head onto the four cushions ③ of the desk. Then, install the machine head onto the machine bed that has two openings with rubber cushion ② of each. (Fig. 10, 11)

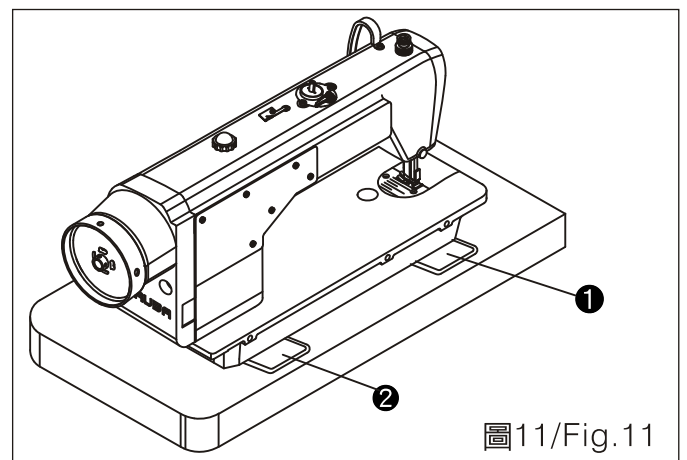
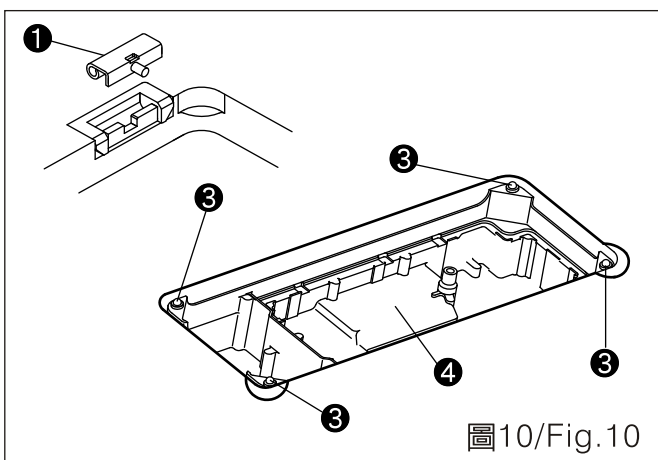

## 針的安裝

請依線規格及布料選用正確型號的針。先關掉電源，再開始安裝針。（圖 12）

1. 轉動手輪使針棒位於行程最高點。
2. 放鬆螺絲②並握住針①，使其針頸內弧部份 A 正確面向右方 B。並檢視針之長溝 C 確實面向左 D。

## INSTALLING THE NEEDLE

Choose a right needle size according to the type of the thread and the type of the material used. Turn the power off before placing the needle. (Fig. 12)

1. Turn the hand wheel to raise the needle bar to its highest position.
2. Loosen screw ②, and hold the needle ① with its indented side A facing exactly to right in direction B, and make sure that long groove C of the needle is facing exactly to the left in direction D.



圖12/Fig.12

## 梭子之安裝

1. 安裝梭子於梭殼中，使捲線方向為如圖示方向。（圖 13）
2. 將針線穿過縫隙 A 處，並朝 C 方向拉線，如此，針線將穿過壓力彈簧①，並由 B 處缺口穿出。
3. 當向 C 拉線時，梭子是順著箭頭所指方向轉動。

## SETTING THE BOBBIN

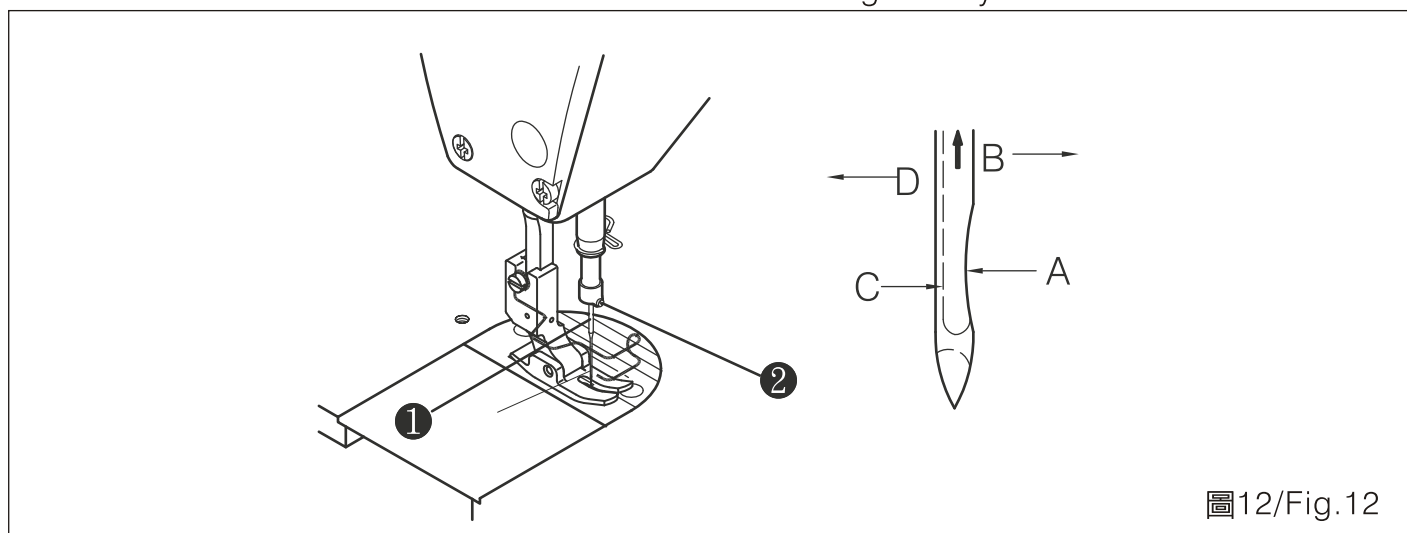
1. Set the bobbin in the bobbin case in the way that the thread wound direction is clockwise. (Fig. 13)
2. Pass the thread through thread slit A, and pull the thread in direction C. The thread will be pulled under the tension spring ① and will be pulled out from notch B.
3. Be sure the bobbin rotates in the direction as the arrow shows when thread is pulled toward C.



圖13/Fig.13

## 線架安裝

## THREAD STAND ASSEMBLY

1. 安裝線架組，並將其插入桌板孔(圖14)。

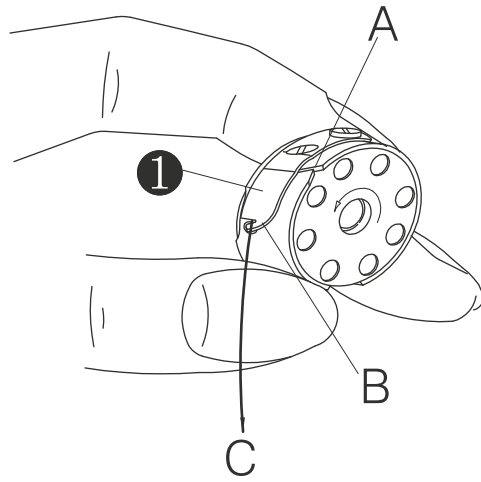
1. Assemble the thread stand set before installing. Place the thread stand set onto the hole on the table top. (Fig. 14)

2. 鎖緊螺帽①，以固定線架。

2. Fix the thread stand with a nut ① locked under the table top.



圖14/Fig.14



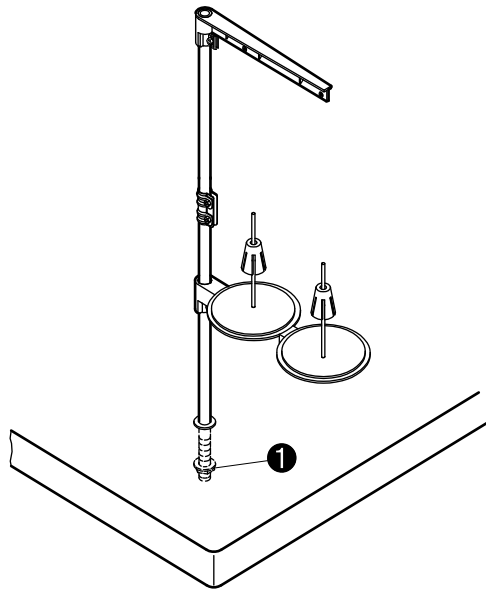

圖15/Fig.15

1. 依箭頭指示方向轉動縫距調整鈕①，並將所需數字對準標點 A。（圖 16）
2. 調整鈕上刻度單位是公厘。
3. 當要調整縫距時，轉動縫距調整鈕①，同時將搖桿②往下壓。

1. Turn stitch length dial ① as the arrow indicates to have the desired number align with mark A on the machine (Fig. 16)
2. The calibration on the dial is millimeters.
3. Press the feed lever ② down and turn the stitch length adjustment dial ① to change stitch length.

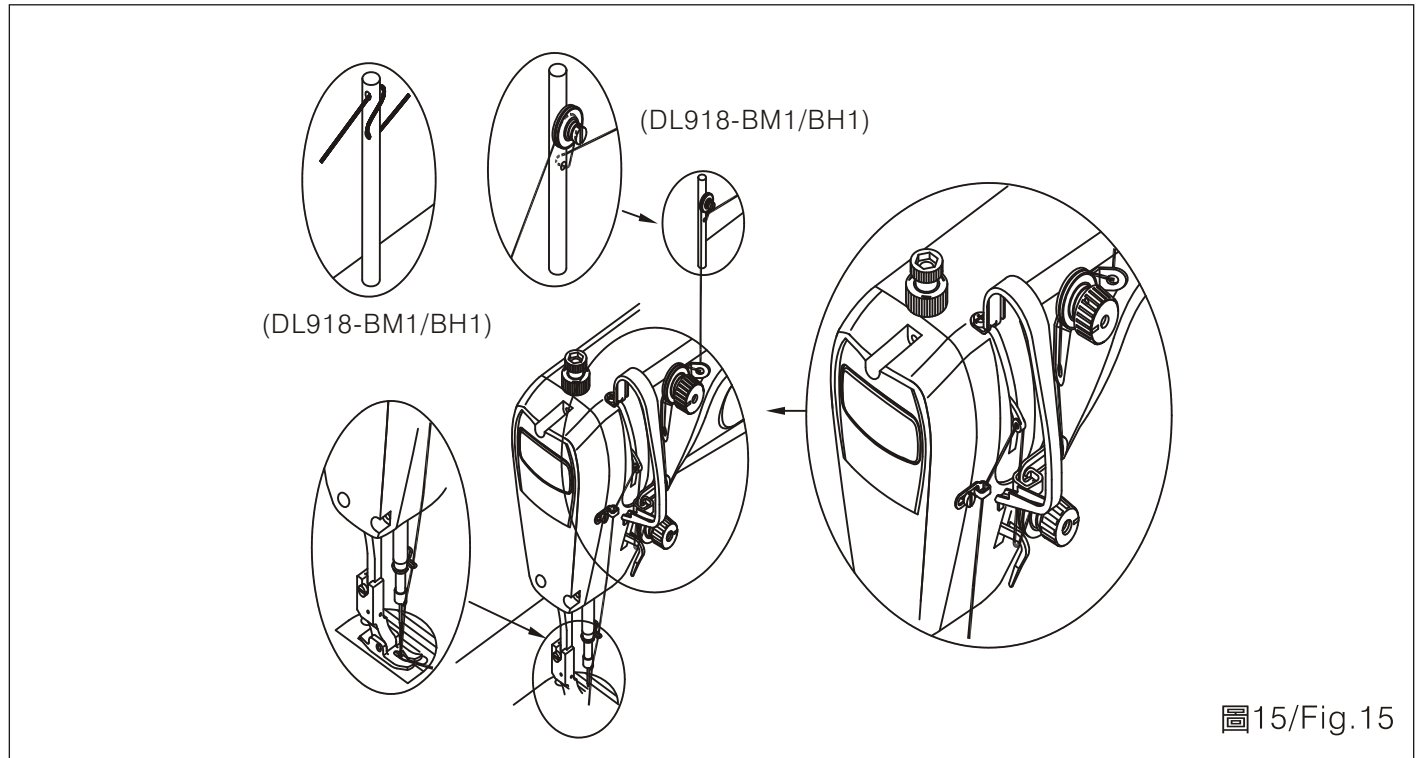

圖16/Fig.16

## 膝控壓具提升器之調整

1. 使用膝控壓具提升器，標準的壓具提升高度是 10mm。（圖 17、18）
2. 可以使用膝控壓具提升器調整螺絲①，將壓具提高至 13mm。
3. 當壓具調整高度超過 10mm 時，請確認針棒最底部②是否會觸及壓具③上部。

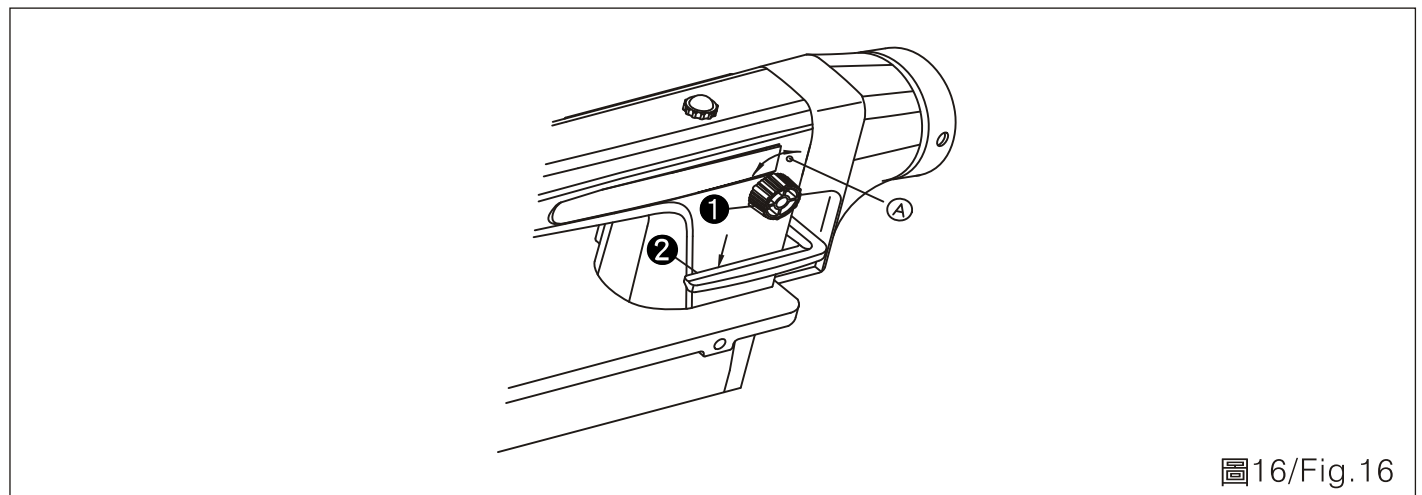
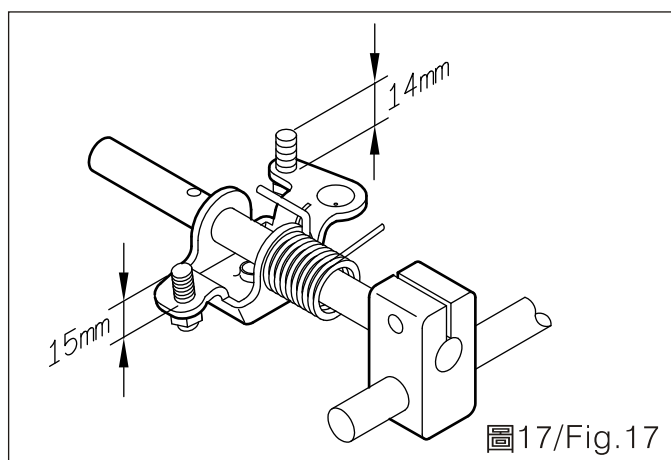

## ADJUSTMENT OF KNEE-CONTROL PRESSER FOOT LIFTER

1. The standard lifting height is 10 mm by using knee-control presser foot lifter. (Fig.17, Fig.18)
2. V adjusting the screw ① at the knee controller, the presser foot can be lifted up to 13 mm.
3. When the presser foot is adjusted to be lifted over 10 mm, assure the bottom end of the needle bar ② in its lower position ③ does not hit the presser foot.

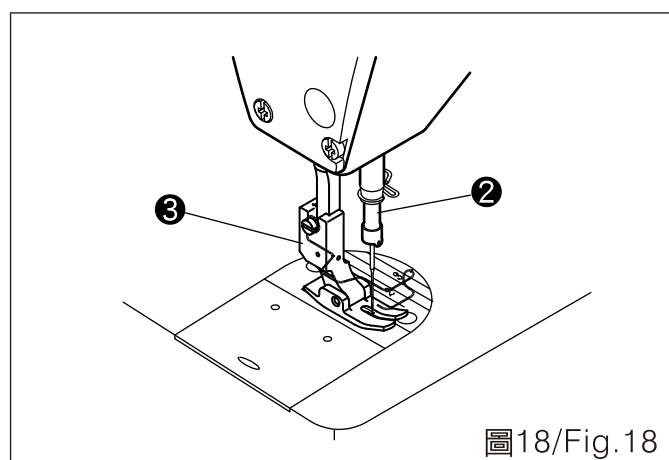

## 針線梭線鬆緊度調整

1. 針線鬆緊度調整（圖 19）
  - (1) 依順時鐘方向（A 方向）轉動針線鬆緊控制鈕①，切線後留在針頭之線量變短。
  - (2) 依逆時鐘方向（B 方向）轉動針線鬆緊控制鈕①，線量變長。
  - (3) 依順時鐘方向（C 方向）轉動針線鬆緊控制鈕②，針線鬆緊度變緊。
  - (4) 依逆時鐘方向（D 方向）轉動針線鬆緊控制鈕②，針線鬆緊度變鬆。

## NEEDLE THREAD/BOBBIN THREAD TENSION ADJUSTMENT

1. Needle thread tension adjustment (Fig. 19)
  - (1) The left thread tail on the needle will be shorter after thread trimmed as you turn thread tension nut ① clockwise. (In A direction)
  - (2) The left thread tail will be longer, as thread tension nut ① is turned counter clockwise (in B direction).
  - (3) Increase the tension on needle thread by turning thread tension nut ② clockwise (in C direction).
  - (4) Reduce the tension on needle thread by turning thread tension nut ② counter clockwise (in D direction).

2. 梭線（底線）鬆緊度調整
  - (1) 依順時鐘方向（E 方向）轉動鬆緊控制螺絲③，底線鬆緊度變緊。
  - (2) 依逆時鐘方向（F 方向）轉動鬆緊控制螺絲③，底線鬆緊度變鬆。

2. Bobbin thread tension adjustment
  - (1) The bobbin thread tension will be increased as tension adjust screw ③ is turned clockwise (in E direction).
  - (2) The bobbin thread tension will be reduced as screw ③ is turned counterclockwise. (In F direction).



圖19/Fig.19

## 控線組彈簧調整

## THE THREAD TAKE UP SPRING ADJUSTMENT

1. 控線組彈簧①行程調整（圖 20）
  - (1) 放鬆螺絲②。
  - (2) 依順時鐘方向（A 方向）轉動鬆緊控制鈕③，控線組彈簧行程將增加。
  - (3) 依逆時鐘方向（B 方向）轉動鬆緊控線鈕③，控線組彈簧行程將減少。
2. 控線組彈簧①拉力調整
  - (1) 放鬆螺絲②，同時將控線彈簧組⑤拆下。
  - (2) 放鬆螺絲④。
  - (3) 依順時鐘方向（A 方向）轉動鬆緊控線鈕③，控線組彈簧拉力將增加。

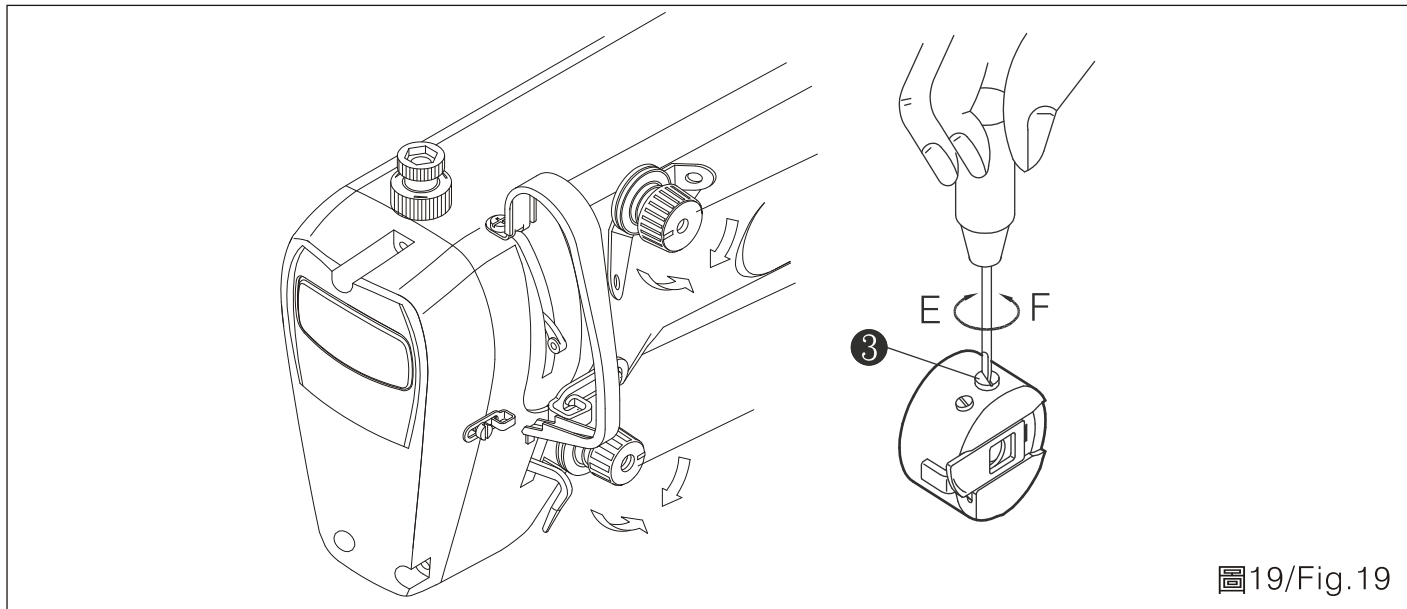
1. Adjusting the stroke of thread take up spring ① . (Fig. 20)
  - (1) Loosen screw ② .
  - (2) The stroke of the thread take-up spring will be increased as the tension knob ③ is turned clockwise (in A direction).
  - (3) The stroke will be decreased as the knob ③ is turned counter-clockwise (in B direction).
2. Adjusting the pressure of thread take up spring ① .
  - (1) Loosen screw ② , and remove thread tension disks ⑤ .
  - (2) Loosen screw ④ .
  - (3) The pressure will be increased as tension knob ③ is turned clockwise (in A direction).

(4) 依逆時鐘方向 (B 方向) 轉動鬆緊控線鈕③，控線組彈簧拉力將減少。

(4) The pressure will be reduced as tension knob ③ is turned counter clockwise (in B direction).



圖20/Fig.20

### 壓具提升桿

### MANUAL PRESSER FOOT LIFTING LEVER

1. 將機器停止，順著 A 方向轉動壓具提升桿①。（圖 21）
2. 壓具往上提升約 5.5mm，並固定之。當順著 B 方向往下轉動壓具提升桿時，壓具將降回至原位置。

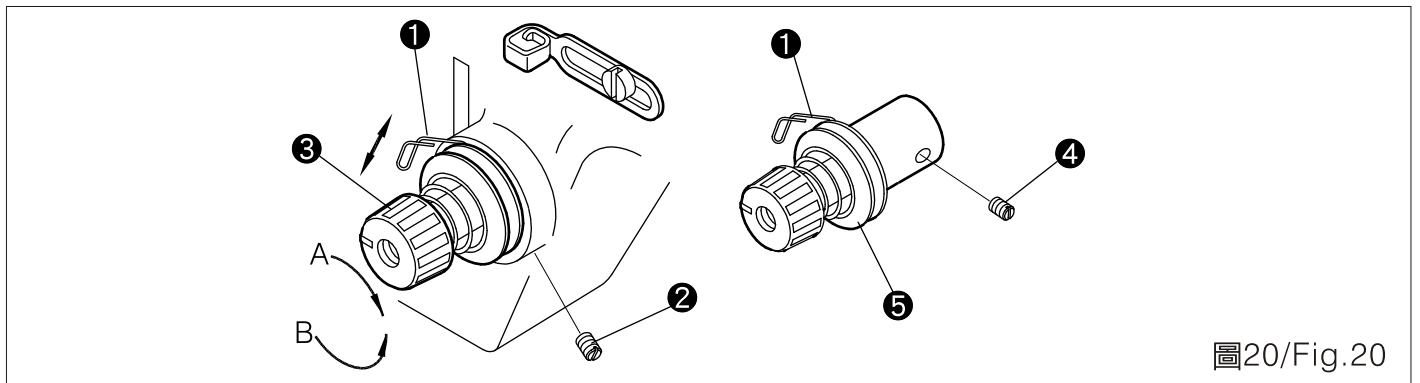
1. Stop the machine and turn the presser foot lifting lever ① up (in A direction) to keep it up. (Fig. 21)
2. The presser foot will remain at that position. Turn hand lifter lever ① down (in B direction) to release presser foot to its original position.



圖21/Fig.21

### 壓具壓力調整

### ADJUSTING PRESSER FOOT PRESSURE

1. 放鬆螺母②，依順時鐘方向 (A 方向) 轉動壓具壓力調整鈕①時，壓力增加。（圖 22）

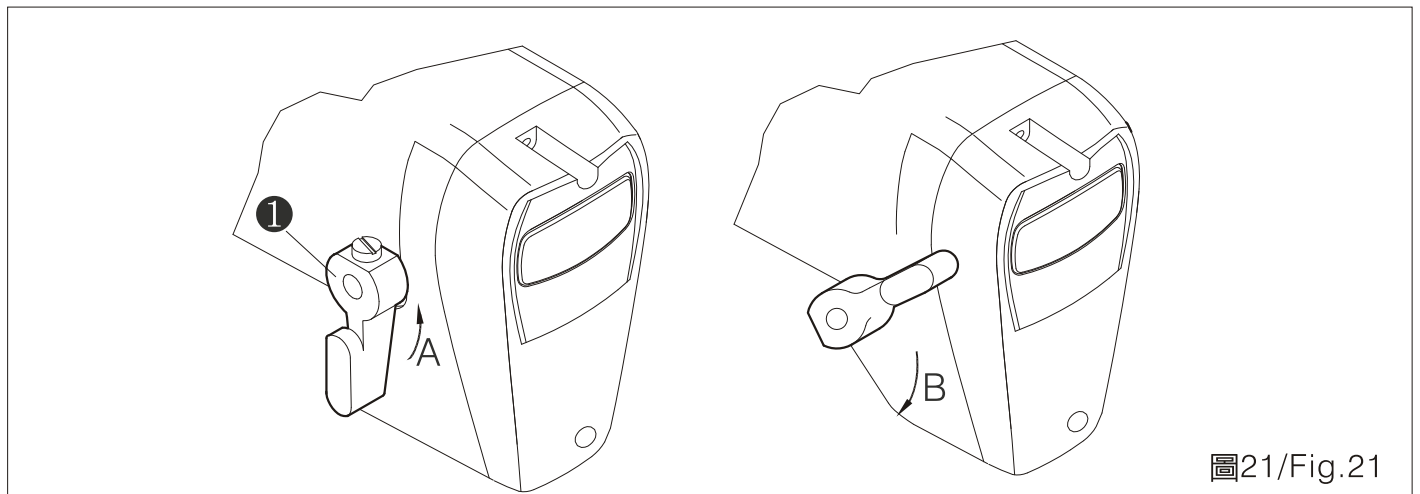
1. Loosen nut ②, turn presser spring regulator ① clockwise (in A direction) to increase the presser foot pressure. (Fig.22)

2. 依逆時鐘方向 (B 方向) 轉動壓具彈力調整鈕①時，壓力減少。
3. 調整完畢，鎖緊螺母②。一般布料壓具壓力調整鈕之調整壓力為 5kg，厚布料為 7kg。(依布料之厚薄，適當調整壓具之壓力，才能得最佳之車縫效果)

2. Turn presser spring regulator ① counter clockwise (in B direction) to reduce the presser foot pressure.
3. Lock nut ② after adjustment is done. For regular fabric, the normal pressure of the presser foot should be set at 5kg, for heavy fabric is 7kg. (To have the best sewing result, please adjust the proper presser foot pressure according to the material.)

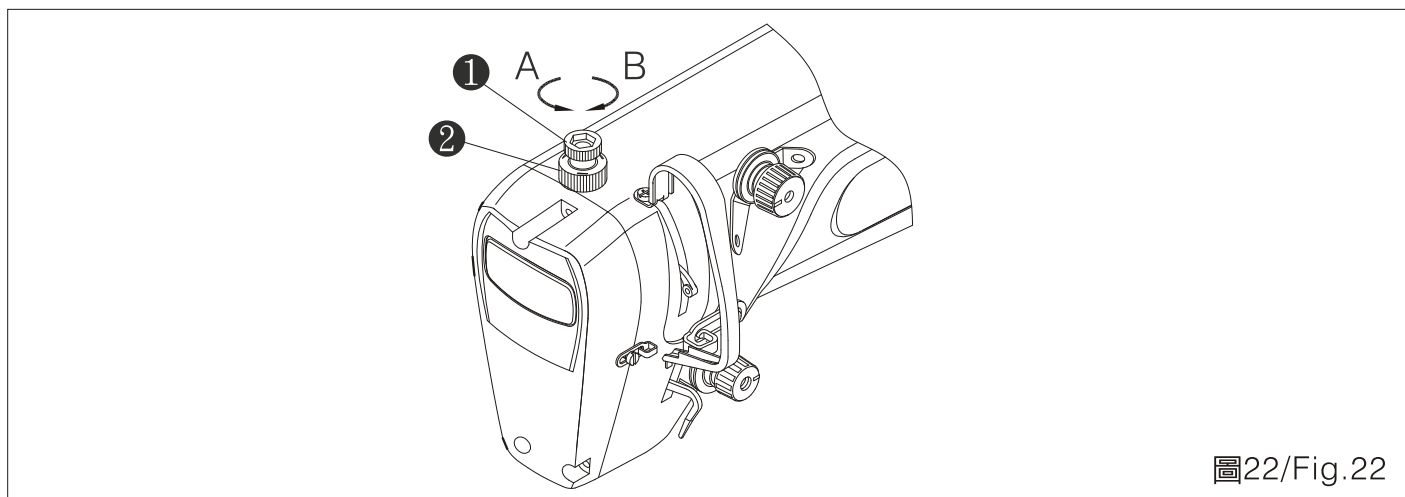

## 針與送具時位調整

## ADJUST THE TIMING BETWEEN NEEDLE AND FEED DOG

1. 放鬆偏心凸輪①上之②及③螺絲，再依箭頭或反箭頭方向轉動偏心凸輪①後，再鎖緊螺絲。(圖 23)
2. 一般標準時位調整：當針孔下降至針板面時，將送具齒端上緣及針之針孔上緣調整與針板上緣成一線。(圖 23-a)
3. 提前送具時位調整：如果為了防止送料偏斜，將偏心凸輪①依箭頭方向調整，把送具時位提前。(圖 23-b)
4. 延遲送具時位調整：如欲增加車縫緊度，則將偏心凸輪①依反箭頭方向轉動把送具時間延後。(圖 23-c)

1. Loosen screws ② and ③ on the feed eccentric cam ①, move the feed eccentric cam ① in the direction of the arrow or the opposite direction of the arrow, and lock the screws firmly. (Fig. 23)
2. Standard timing adjustment: when the upper side of the needle hole travels down to the needle plate surface, adjust the upper sides of the feed dog teeth and the needle hole to be at the same level of the needle plate upper surface. (Fig.23-a)
3. Antedates timing adjustment: to prevent the fabric deflected from feeding, turn the eccentric cam ① by the arrow direction to antedate the feed timing. (Fig. 23-b)
4. Delayed timing adjustment: to increase the stitch tension, extend the feed eccentric cam ① in the opposite direction of the arrow. (Fig.23-c)

注意：  
不可將偏心凸輪①移動過大，以免可能引起斷針。

Attention:  
Please do not move the feed eccentric cam ① too far to avoid needle breakage.



圖23/ Fig.23

## 送具傾斜度

## ADJUST THE ANGLE OF TILT OF THE FEED DOG

1. 當在送料具軸上的 A 與 B 成一線時，送具之傾斜度即成水平狀態。（圖 24-a）
2. 為了避免車縫起皺，以螺絲起子放鬆螺絲①，將送具偏心軸②依箭頭方向轉動 90 度，可抬高送具後緣，成前傾狀態。（圖 24-b）
3. 為了避免布料送料不足，用螺絲起子放鬆螺絲①，將送具偏心軸②依箭頭 b 方向轉動 90 度，可使送具前緣抬高，成後傾狀態。（厚布料調整時）（圖 24-c）
4. 送具傾斜度調整過後，送具高度會改變，所以送具傾斜度調整後須再檢查其高度。

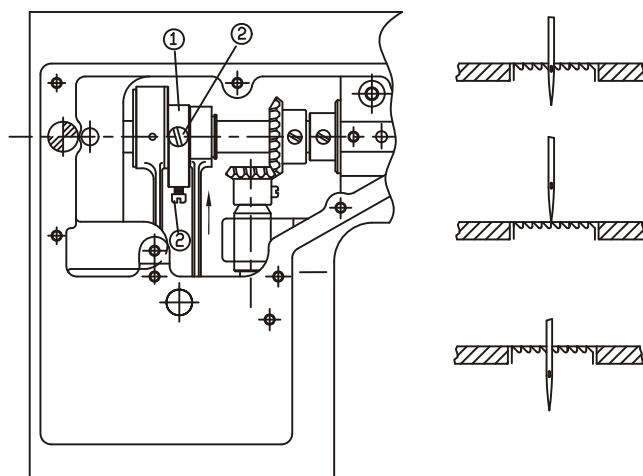
1. When mark A on the feed bar shaft ② is aligned with mark B, the angle of the feed dog becomes horizontal. (Fig. 24-a)
2. To prevent fabric from puckering, loosen the screw ① by a screw driver and turn the feed dog eccentric shaft ② 90 ° in the direction of the arrow to reduce the front tilt angle of the feed dog and to form a tilting-front status. (Fig.24-b)
3. To prevent uneven fabric feeding, please turn the feed dog eccentric shaft ② 90 ° opposite to the arrow direction. This could decrease the backward tilt angle of the feed dog and to form a tilting-back status. (For adjusting the thick materials). (Fig.24-c)
4. After adjusting the tilt angle of the feed dog, this will change the height of the feed dog. Therefore, please recheck its height after adjusting the tilt angle of the feed dog.



圖24/Fig.24

## 送具高度

## ADJUSTING THE HEIGHT OF THE FEED DOG

1. 送具高度（送具超出針板面的高度）在出依照布料厚薄調整如下：（圖 25-a/b）

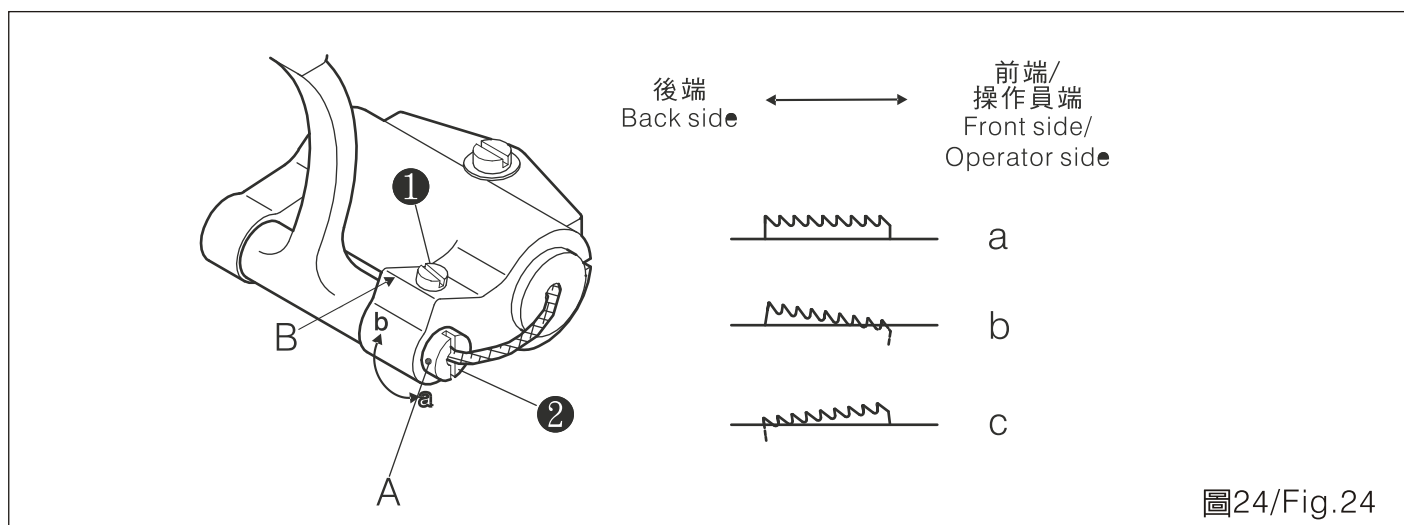
中厚布料：0.85~0.95mm（圖 25-a）

厚布料：1.0~1.2mm（圖 25-b）

2. 如果送具太過突出，車薄布料時可能引起皺紋。

3. 送具高度調整：

(1) 放鬆曲柄①螺絲②。

(2) 上下移動曲柄①使送具座升高或下降來加以調整。

(3) 再鎖緊螺絲②。

4. 勿使滑塊③與曲柄①之開口部份銜接不緊，否則曲柄①之開口部分將會磨損。

1. The feed dog height (the height of the feed dog emerged from the needle plate surface) is set by the fabric thickness as the followings: (Fig.25-a/b)

Normal fabric: 0.85~0.95 mm (Fig.25-a)

Heavy fabric: 1.0~1.2 mm (Fig.25-b)

2. If the feed dog is emerged too much, it is very easily to form the puckers when sewing thin fabrics.

3. To adjust the feed dog height:

(1) Loosen screw ② on crank ① .

(2) Move the crank ① up and down to move the feed bracket up and down to adjust to.

(3) Lock the screw ② securely.

4. The crank's ① opening will be worn out if the clamping pressure between roller ③ and crank ① is not enough.



圖25/Fig.25

1. 針與梭頭時位調整如下：轉動手輪使針棒降至最低點（下死點），並放鬆螺絲①。（圖 26）

(1) 調整針棒高度：

(DB 針) 將針棒②上之標線 A 對齊針棒下襯套③底部，然後鎖緊固定螺絲①。

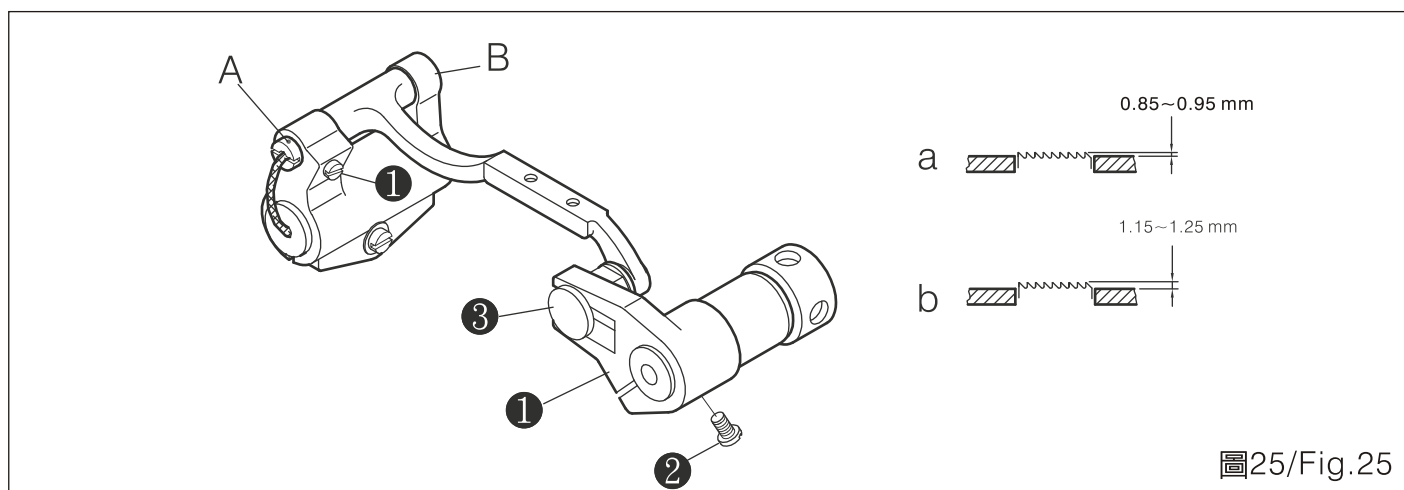
(DA 針) 將針棒②上之標線 C 對齊針棒下襯套③底部，然後鎖緊固定螺絲①。

(2) 調整梭頭之位置：

(DB 針) 放鬆梭頭之 3 個固定螺絲，轉動手輪將針棒②上之標線 B 對齊針棒下襯套③底部。

(DA 針) 放鬆梭頭之 3 個固定螺絲，轉動手輪將針棒②上之標線 D 對齊針棒下襯套③底部。

(3) 經上述調整步驟後，將梭頭尖⑤與針中心④對齊，且車針與梭頭尖之間隙為 0.05~0.1mm 最為適當。

2. 更換梭頭時，先確認其零件代號再更換。

1. The timing adjustment between needle and hook is: turn the hand wheel to lower the needle bar down to the lower dead point of its stroke, and loosen the screw ①. (Fig. 26)

(1) Adjusting the height of needle bar:

- (DB needle) Align the mark line A on needle bar ② with the bottom edge of needle bar lower bushing ③, and then tighten the setscrew ①.
- (DA needle) Align the mark line C on needle bar ② with the bottom edge of needle bar lower bushing ③, and then tighten the setscrew ①.

(2) Adjusting the position of the hook:

- (DB needle) Loosen the three setscrews on the hook, and turn the hand wheel to align the mark line B on ascending needle bar ② with the bottom edge of needle bar lower bushing ③.
- When a DA needle is used loosen the three setscrews on the hook, turn the hand wheel, and align marker line D on ascending needle bar ② with the bottom edge of needle bar lower bushing ③.

(3) After the adjustments mentioned above are done, align hook blade point ⑤ with the needle center ④. Keep it at the ideal clearance of 0.05~0.1 mm between the needle and the hook.

2. Specify the correct part number before replacing hooks.



注意：

如果梭尖與針之間隙太短使得梭尖碰觸針，則梭尖將會容易受損；如果間繫過大，將容易會引起跳針。

Attention:

If the clearance between the hook tip and the needle is less than the identified value, the hook tip will touch the needle and cause the damage of the hook tip happened easily. If the clearance is too wide, stitch skipping will occur easily.

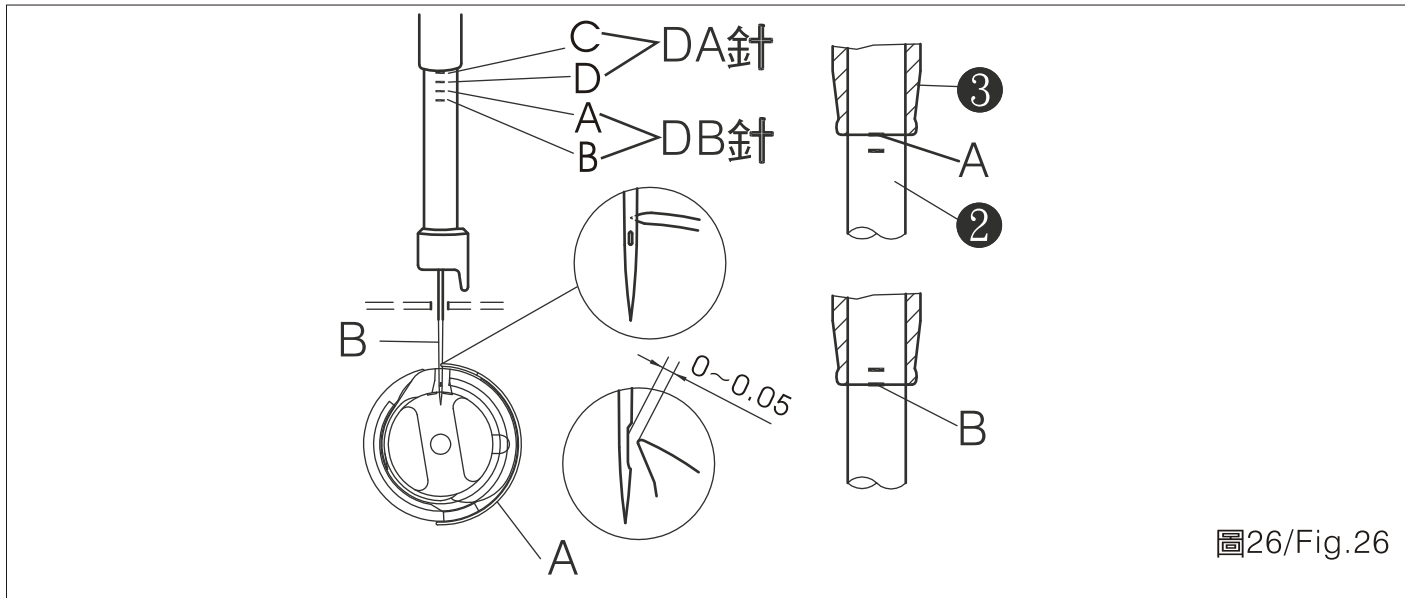

### 壓具高度調整

1. 放鬆固定螺絲①，並調整壓具高度及角度。（圖 27）
2. 調整後，確實鎖緊固定螺絲①。

### PRESSER FOOT HEIGHT ADJUSTMENT

1. Loosen screw ①, and adjust the height of presser foot and its orientation. (Fig. 27)
2. After adjustment, lock the screw ① securely.

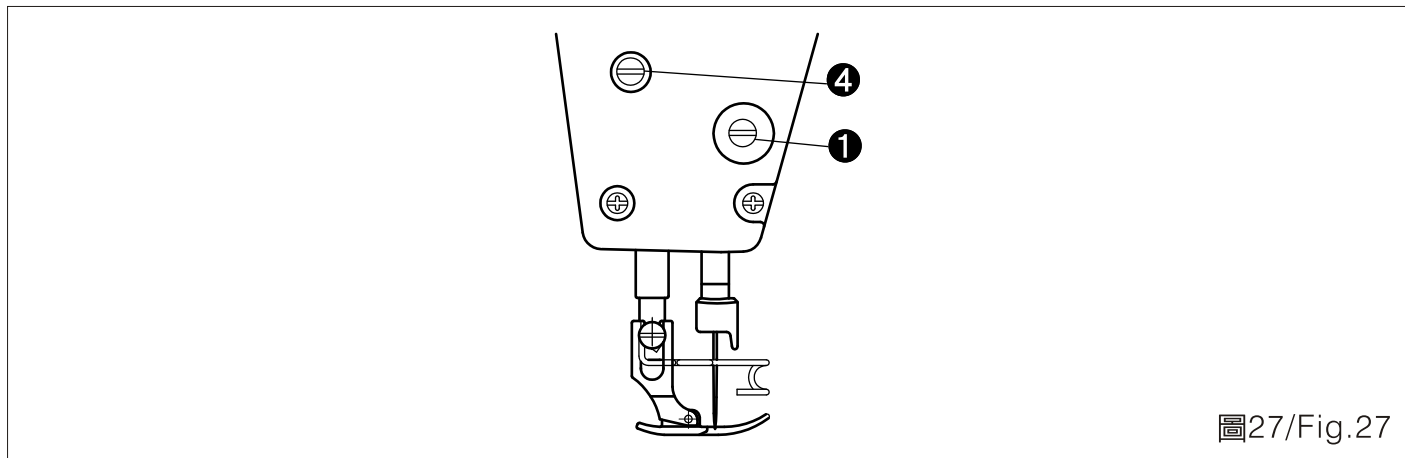

## 導線片之調整

1. 當車縫厚布料時，將導線片①往左（A方向）移動，以增加挑線桿之拉線量。（圖 28）
2. 當車縫薄布料時，將導線片①往右（B方向）移動，以減少挑線桿之拉線量。
3. 一般導線片①是放在其標線 C 與螺絲中心對齊位置。

## THE THREAD TAKE-UP STROKE ADJUSTMENT

1. Move thread guide ① to the left (in direction A) to increase the amount of thread pulled out by the thread take-up when sewing heavy fabric. (Fig.28)
2. Move thread guide ① to the right (in direction B) to decrease the amount of thread pulled out by the thread take-up when sewing light-weight materials.
3. In general, thread guide ① is positioned to have the marker line C aligned with the center of the screw.

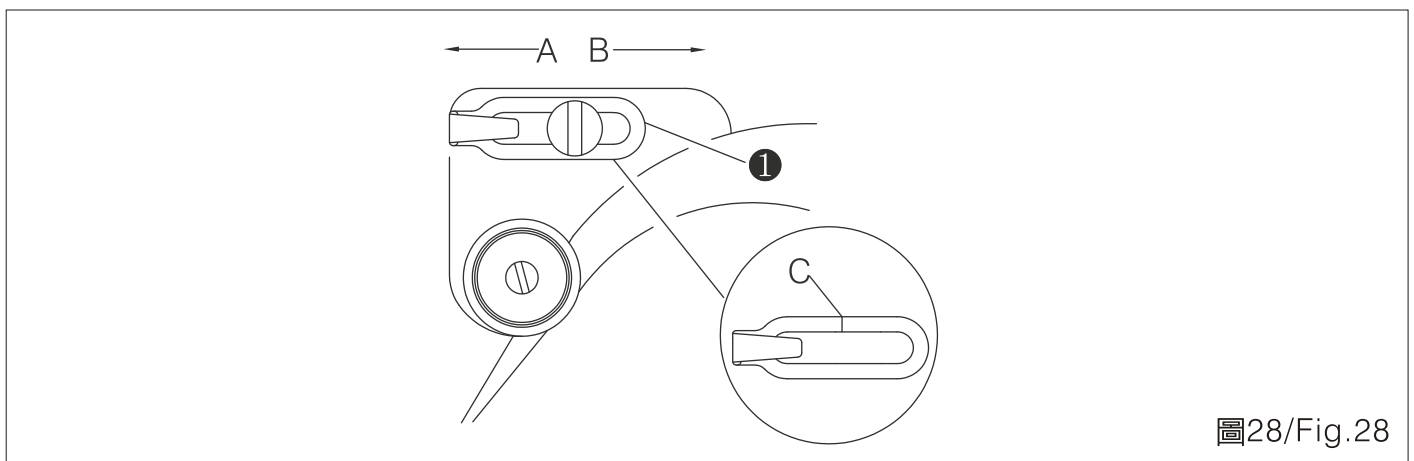

## 腳踏板壓力及行程

1. 腳踏板前踩位置的壓力調整。（圖 29）
  - (1) 腳踏板壓力可經由改變腳踏板壓力調整彈簧①之安裝位置而改變。
  - (2) 將彈簧勾移往左邊，壓力減少。
  - (3) 將彈簧勾移往右邊，壓力增加。
2. 腳踏板後踩位置的壓力調整。
  - (1) 壓力可經由調整螺絲②調整。

## ADJUSTING THE TENSION ON PEDAL AND PEDAL STROKE

1. Adjusting the front part treading pressure of the pedal. (Fig. 29)
  - (1) The pressure of the pedal can be adjusted by changing the mounting position of pedaling pressure adjust spring ① .
  - (2) The pressure is reduced when moving the spring hook to left side.
  - (3) The pressure is increased when moving the spring hook to right side.
2. Adjusting the rear part treading pressure of the pedal.
  - (1) The rear part threading pressure of the pedal can be adjusted by driving the regulator screw ② .

(2) 將調整螺絲依箭頭方向，壓力增加。

(3) 將調整螺絲反箭頭方向，壓力減少。

### 3. 腳踏板行程調整

當將連接桿③移往左邊孔方向時，腳踏板行程減少。

(2) The pressure is increased when you follow the direction on the screw to drive it.

(3) The pressure is decreased when you drive the screw by the opposite direction of the arrow on the screw.

### 3. Adjusting the pedal stroke.

The pedal stroke is shorter as connecting rod ③ moved to the left holes.

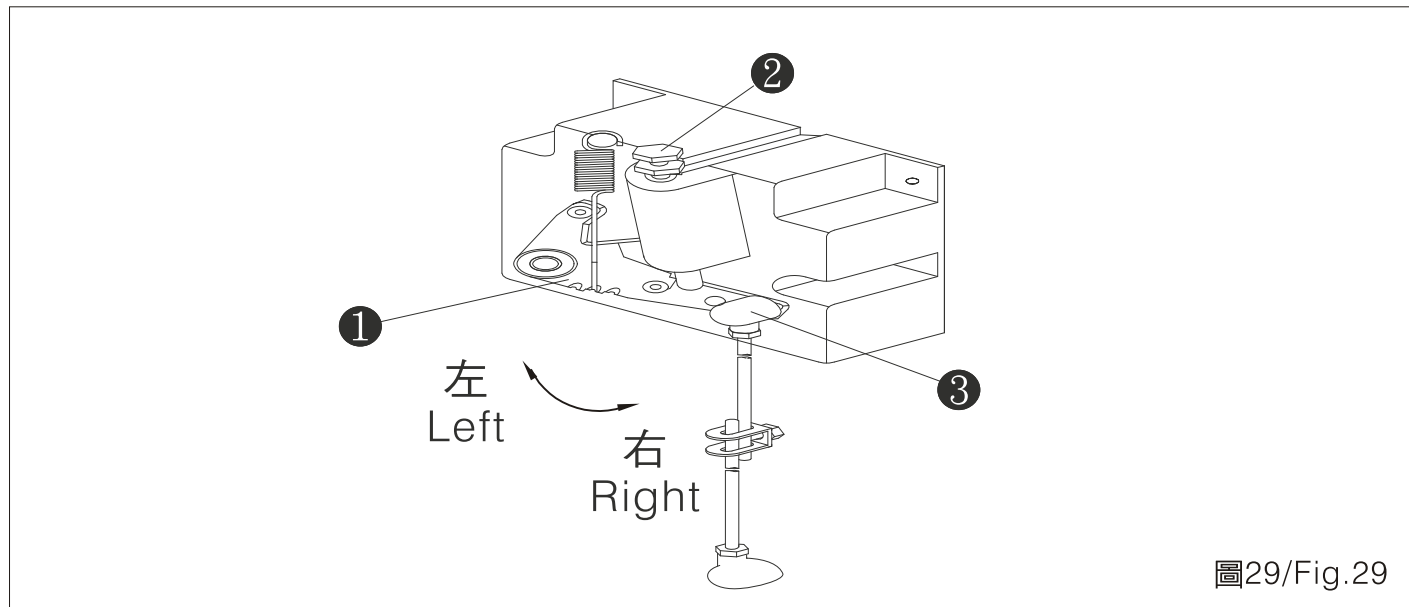

## 腳踏板調整

## ADJUSTING THE PEDAL

### 1. 連接桿安裝 (圖 30)

依圖箭頭方向所示，左右移動腳踏板③，使馬達控制桿①與連接桿②成一直線。

### 2. 腳踏板傾斜度調整

(1) 腳踏板傾斜度可藉著改變連接桿長度而自由調整。

(2) 放鬆調整螺絲④調整連接桿②長度。

### 1. Install the connecting rod. (Fig.30)

Move the pedal ③ left and right as the arrow shows in the figure in order to align the motor control lever ① with the connecting rod ②.

### 2. Adjusting the slope of the pedal

(1) The tilt degree can be changed and adjusted freely by changing the length of the connecting rod.

(2) The length of the connecting rod ② is adjusted by loosening the adjusting screw ④.



圖30/Fig.30

### 撥線桿調整

### ADJUSTING THE THREAD WIPER

1. 撥線桿位置。(圖 31、32、33)  
請依車縫布料厚薄，調整撥線桿位置。
2. 調整撥線桿平坦部位與針中心距離 1mm，鎖緊撥線桿調整螺絲⑤，使撥線桿被其鎖圈⑥壓住及固定。
3. 不用撥線桿時，請將其開關⑦切掉。

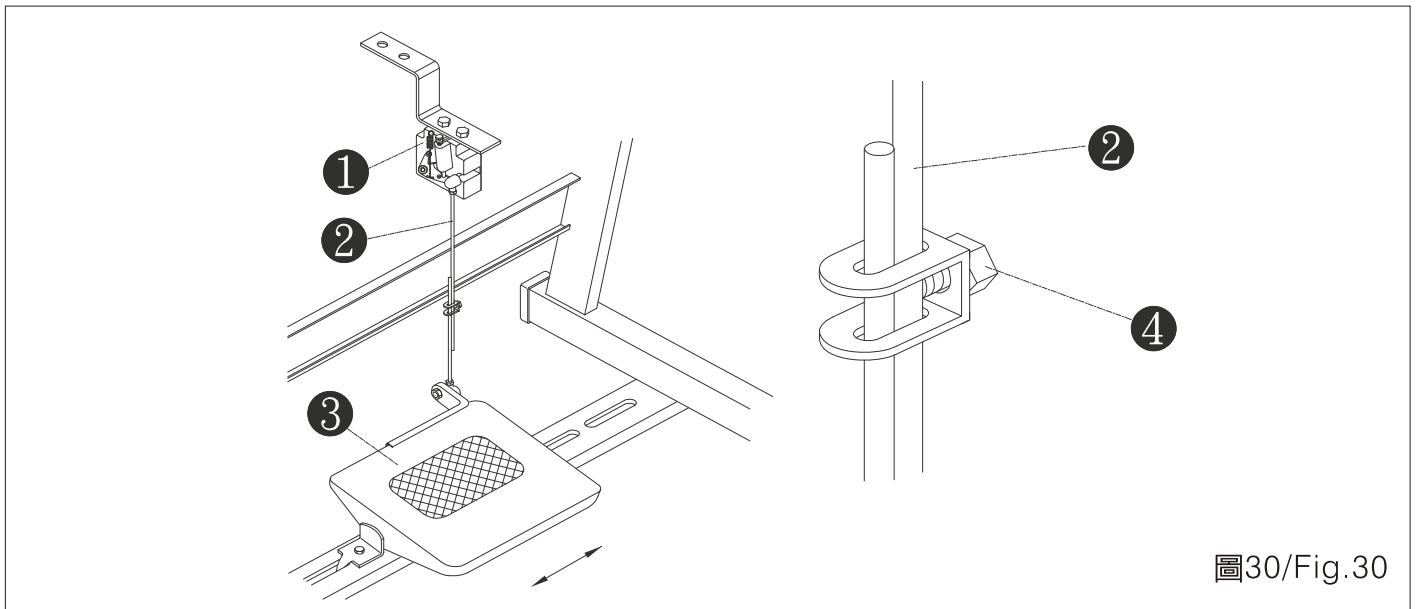
1. The thread wiper location. (Fig.31,32,33)  
Please adjust the thread wiper according the thickness of the materials.
2. Adjust the flat straight part of the thread wiper in a distance of 1 mm from the center of the needle. Lock the adjust screw ⑤ of the thread wiper can be fixed and firmly pressed by its cocollar ⑥ .
3. Please turn off the thread wiper switch ⑦ when there is no necessary to use the thread wiper.



圖31/Fig.31



圖32/Fig.32

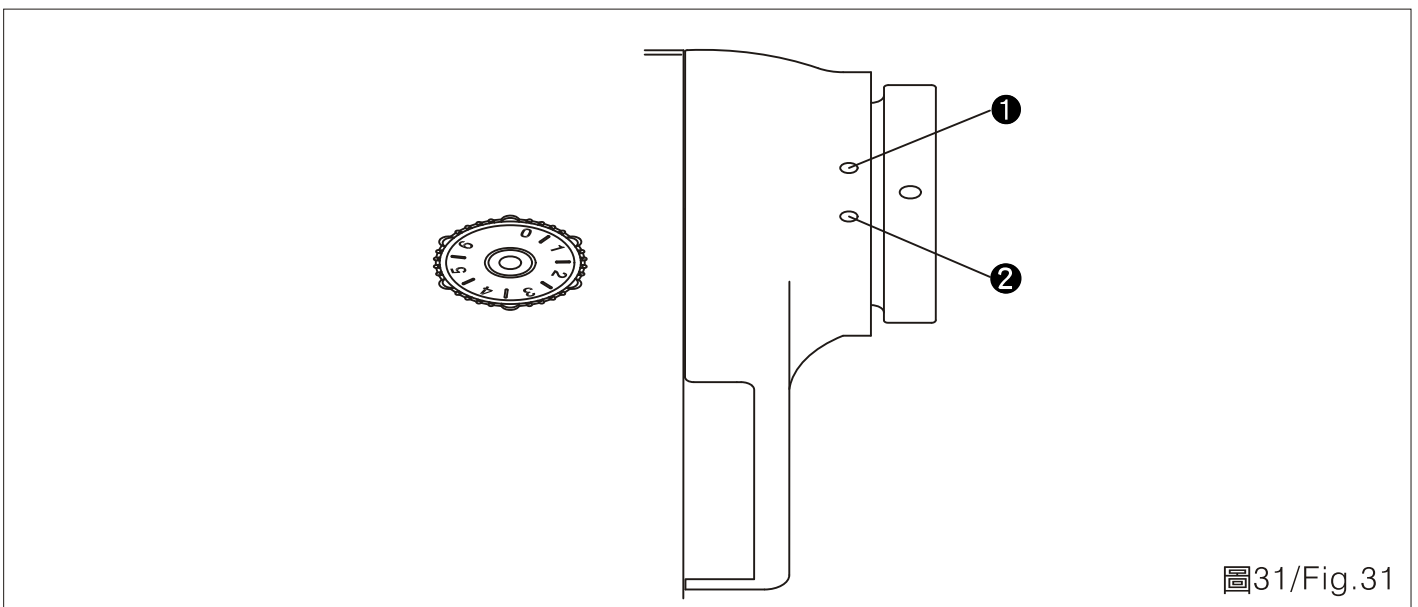

圖33/Fig.33

## 梭頭油量調整

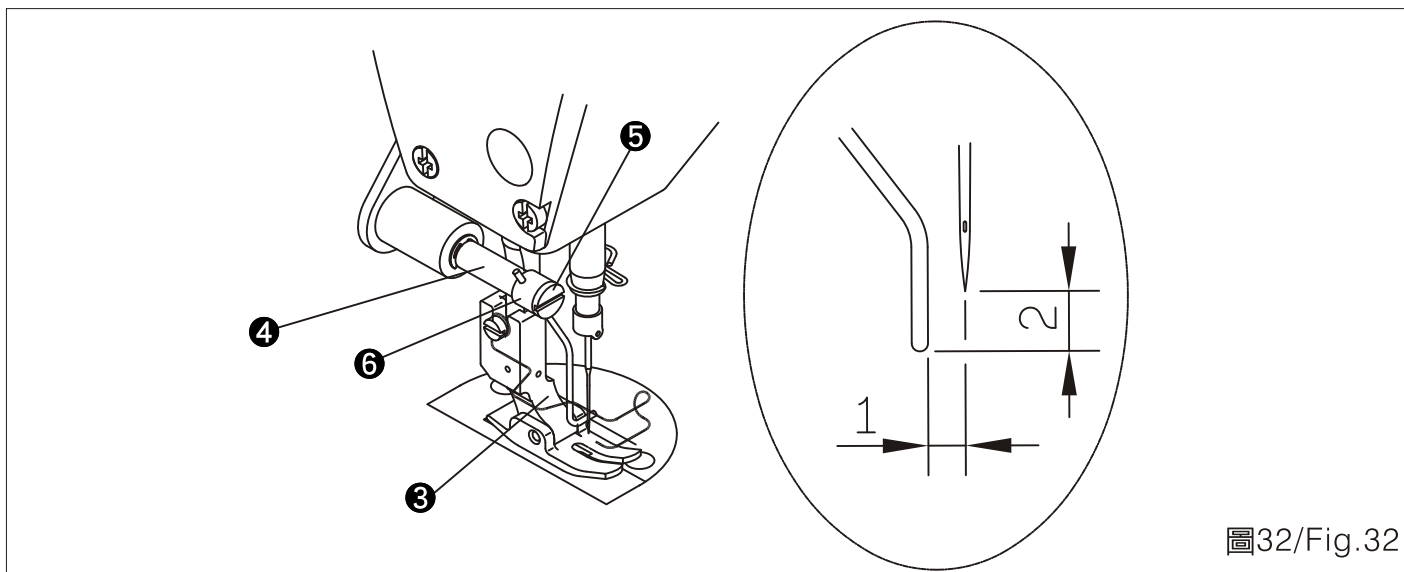
1. 轉動裝在梭頭傳動大心上之油量調整螺絲，轉向 "+" 號方向（順著 A 方向）油量增加；轉向 "-" 號方向（順著 B 方向）油量減少。（圖 34）
2. 梭頭油量適當調整後，將機器空轉 30 秒，以重新檢查確認梭頭油量。

## ADJUSTING THE AMOUNT OF OIL IN THE HOOK

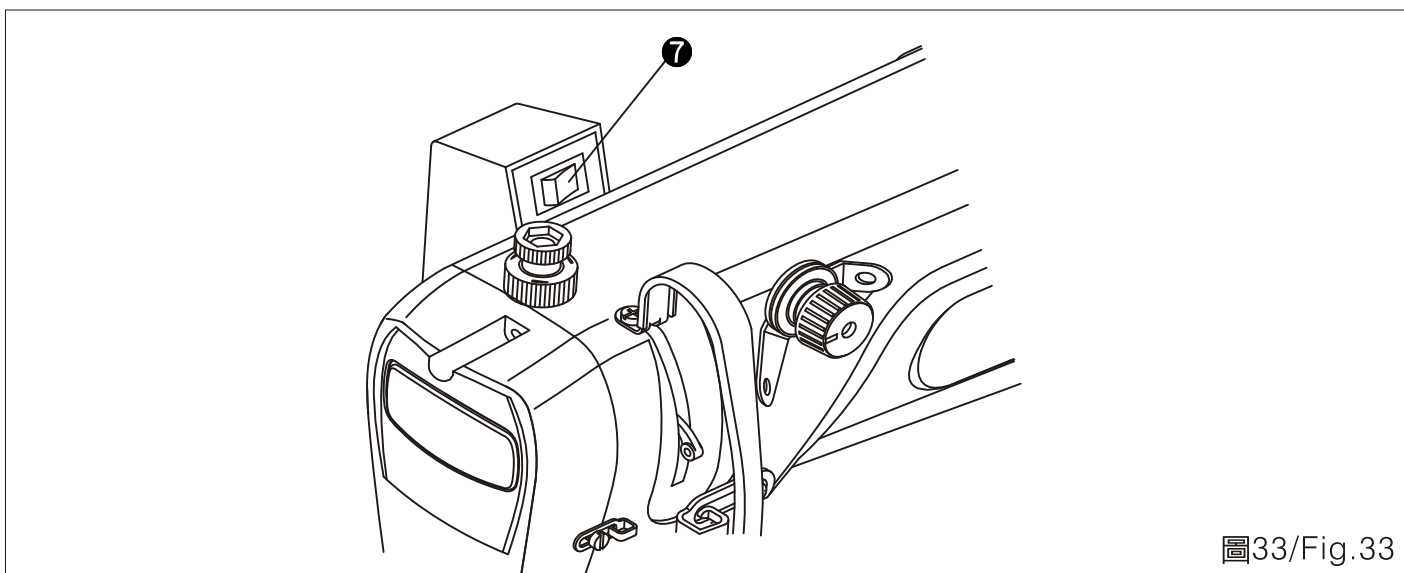
1. The oil amount adjustment screw is mounted on the hook driving shaft. Turn the screw counter clockwise toward "+" direction (A direction) to increase the amount of oil supplied in the hook. Turn the screw clockwise toward "-" direction (B direction) to reduce the amount of oil supplied in the hook. (Fig. 34)
2. After the amount of oil in the hook is properly adjusted, run the machine idly for 30 seconds to do oil splashing observation test to reconfirm the amount of oil in the hook.



圖34/Fig.34

### 操作環境照明

提供一個警示標誌，告知使用者：工業用縫紉品或是縫紉系統必須在該縫紉區域未啓動照明裝置前，禁止插電或通電；照明裝置的最大輸入功率應該能夠輕易辨識，當照明裝置被重置或移動的時候，警示標誌也應設置在照明裝置插座上或是附近。警示標示如圖 35 所示。

### LIGHTENING OF THE OPERATION ENVIRONMENT

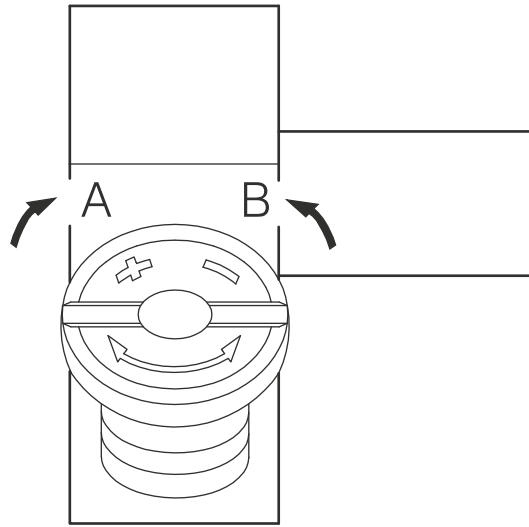
Provide a warning that an industrial sewing unit or sewing system must always be unplugged from the local lighting of the sewing area before relamping, the marking of maximum rated input of a lamp shall be easily discernible while the lamp is being replaced indicated on or near the lamp socket as shown on Fig. 35.

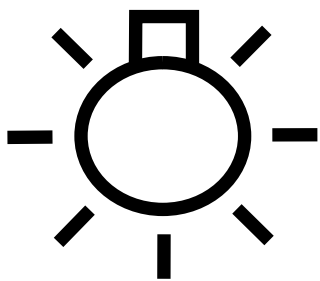

最大流明.....510 流明  
 Maximum.....510 Lum  
 最小流明.....430 流明  
 Minimum..... 430 Lum

圖35/Fig.35

## 操作者條件

1. 熟讀並了解使用說明書內容。
2. 認識機器各部功能及注意事項。
3. 了解警告標籤之意義。
4. 了解熟悉機器之操作方式。
5. 操作者必須保持精神狀態良好。
6. 操作者須穿著合宜適當之工作服。
7. 適需要培養操作者使用機器之熟練度。

## 腳踏板之操作

腳踏板依以下四步驟操作：（圖 36）

1. 輕踩踏板，如 B，機器將以低速運轉。
2. 進一步重踩踏板前方時，如 A，機器以較高速運轉（如果預先設定有自動倒縫功能，機器將在完成倒縫後再高速運轉）。
3. 踏板恢復至原位置，如 C，機器暫停轉動（針在上或下）。
4. 將踏板完全向後踩，如 E，機器進行切線動作。
5. 注意事項：
  - (1) 如果你的機器附有壓具自動提升器，機器停止與切線動作之間會多了一個步驟，即當你輕輕後踩腳踏板，如 D，壓具向上提升，再往下踩，執行切線動作。

## CONDITIONS OF ALL OPERATORS

1. Read and understand well the content of this instruction book.
2. Know the functions of major parts and understand the notices.
3. Truly realize the meanings of all warning tags.
4. Realize and be familiar with how to operate this machine.
5. Operators have to keep well mental status.
6. Operators shall wear appropriate and proper working suits.
7. Develop the familiarity of how to operate the machine if needed.

## OPERATING THE PEDAL

The foot pedal is operated as the following 4 steps. (Fig. 36)

1. Lightly tread the front part of the foot pedal shown as B in Fig. 36, machine runs at low sewing speed.
2. Further, tread the front part of the foot pedal shown as A. Machine runs at high sewing speed. (The machine runs at high speed after it completes the backstitch if the automatic backstitch has been preset.)
3. Reset the pedal to its original position, shown as C. Machine will stop (with the needle up or down.)
4. Fully depress the back part of the pedal shown as E, so that machine trims threads.
5. Attentions:
  - (1) One extra step is given between the machine stop and thread trimming steps if your machine is equipped with the auto presser foot lifter. When you lightly depress the back part of the pedal, shown as D, the presser foot goes up. The thread trimmer actuates if you further tread the back part of the pedal.

- (2) 當倒縫動作執行時，如果將腳踏板回復到原位置，機器會在倒縫動作完成後才停止。
- (3) 即使機器在高速或低速中，只要立刻將腳踏板往後踩，它都會執行正常的切線動作。
- (4) 如果在機器執行切線動作後，即使立刻將腳踏板恢復原位置 C，機器仍將完成切線動作。
- (5) 當針停在下定位時，如果要將針上提，則將腳踏板後踩一次至 D 位置即可。

- (2) Machine will stop after completing the backstitch if you relocate the pedal to its neutral position during executing the automatic backstitch.
- (3) Whether the machine is under high speed or low speed sewing, you can make the machine doing thread trimming any time by thread down the back part of the pedal to do so.
- (4) Even if you reset the foot pedal to its neutral position C immediately after the machine started thread trimming action, the machine will completely perform thread trimming.
- (5) When the machine stops and makes the needle located at the lower dead end, tread the back part of the foot pedal once to D if you want to bring the needle up.

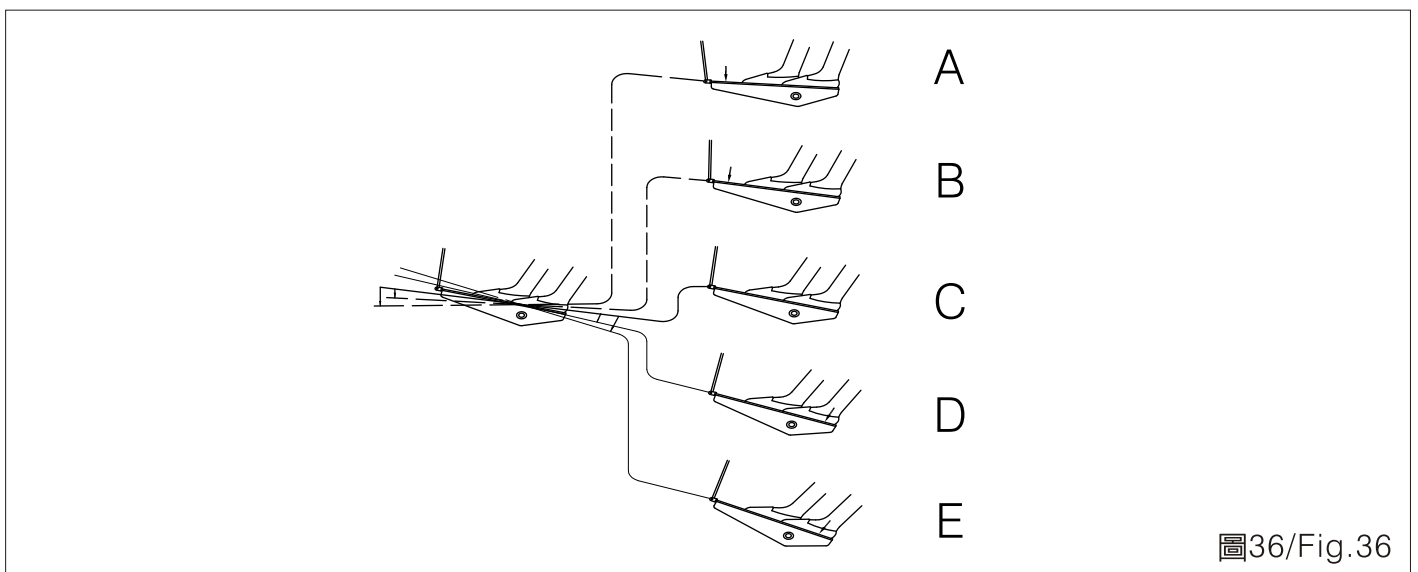

### 單觸式倒縫機構

1. 按下開關①，機器啟動倒縫功能（圖37）。
2. 只要開關持續被按著，機器繼續執行倒縫功能。
3. 開關放鬆，機器即恢復一般車縫功能。

### OPERATING THE ONE TOUCH TYPE REVERSE FEED STITCHING MECHANISM

1. Press the switch lever ① to start the back stitch function. (Fig.37).
2. As long as the switch lever is pressed, the sewing machine will continue doing back stitch.
3. Release the switch lever, and the sewing machine will resume the normal sewing function.





圖37/Fig.37

## 保養

## MAINTENANCE

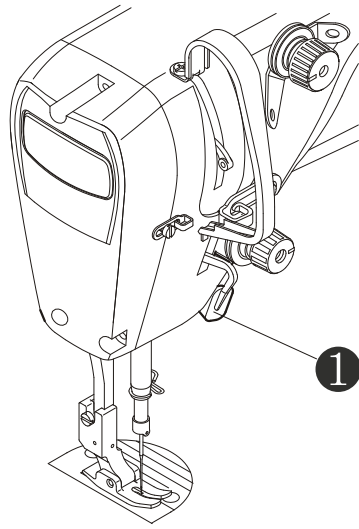

### 注意CAUTION



清潔作業前，請切斷電源。當誤觸啟動開關時，縫紉機動作易導致人員受傷。  
Turn off the power switch before carrying out cleaning. The machine may operate if the treadle is pressed incautiously, which could result in injury.



加潤滑油和黃油時，務必戴好保護眼鏡和手套，以防潤滑油進入眼中或沾在皮膚上，易引起發炎。  
Be sure to wear protective goggles and gloves when handling the lubricating oil and grease so that they do not get into your eyes or onto your skin, otherwise inflammation can be resulted.



潤滑油或黃油不能飲用，否則將會引起嘔吐和腹瀉，將油放在小孩拿不到的地方。  
Furthermore, do not drink or eat the oil nor the grease for they can cause vomiting and diarrhea. Keep the oil away of the reach of children.



縫紉機頭倒下或豎起時，請以雙手進行操作。  
Use both hands to hold the machine head when tilting or returning it to its original position..

單手操作時，因縫紉機的重量較重，萬一滑落易導致受傷。  
If only using one hand to move the machine, the weight of the machine head may cause slipping and you may get hurt.

為了保持縫紉機的機能，且能長久的使用，請每日加以保養。另外，縫紉機如果長時間未使用，請進行以下的保養後再使用。

For keeping the machine quality and lengthening the usage term of this sewing machine, please maintain it everyday. In addition, before first use after a long idling time, please follow the following steps to maintain.

《保養》

1. 抬起押具
2. 將兩個螺絲①拆下，然後拆下針板②。
3. 以軟毛刷清除送布牙③上的布屑。(圖38)
4. 清潔後將針板②裝上。
5. 後傾斜縫紉機頭部。
6. 定期保養項目(表6)

《CLEARNING》

1. Raise the presser foot.
2. Remove two screws①, and then remove the needle plate②.
3. Use a soft brush to clean dust and lints on the feed dog teeth③. (Fig.38)
4. Install the needle plate② after doing the above cleaning.
5. Tilt back the machine head.
6. Periodical Maintenance Items (Table 6)

保養循環 Maintenance Cycle	保養項目 Maintenance Items
每天 Daily	1. 清潔送料具上之棉絮。 1. Clean the lint on the feed dog.
	2. 檢查油盤是否有足夠之液態油。(油量在油鏡之上、下兩紅漆記號間) 2. Check if there has enough liquid oil inside the oil pan. (The amount should be between the red up and down paint mark of the oil level gauge.)
	3. 保持機器及操作台清潔。 3. Keep the machine and the operation table clean.
每週 Weekly	1. 保持電源外觀乾淨。 1. Keep the power cords looking clean and neat.
	2. 保持操作面板乾淨。 2. Keep the operational panel clean.
	3. 檢查電源零件是否鬆脫或在正確位置。 3. Check if the power parts is loosening or still at the right position.
每三個月 Quarterly	1. 更換油盤內之液態油。 1. Replace the liquid oil inside the oil pan.
每年 Annually	1. 檢查傳動皮帶是否疲乏或毀損。 1. Check the transmission belt to see if it is weariful or damaged.

表6 / Table 6



圖38/ Fig.38

## 1. 潤滑說明 (圖 39)

- (1) 使用專用油注入油盤中，液面到高點 A。
- (2) 當液面低於低點 B 時，再添加所指定之潤滑油。
- (3) 如果潤滑正常，當機器操作中，你可以從油盤②中看到噴油現象。
- (4) 當新機器第一次運轉，或經過一段時間未使用，前 10 分鐘試車之轉速，請保持在 3000 到 3500SPM 之間。

## 2. 針棒 / 挑線桿供油量之調整 (圖 40)

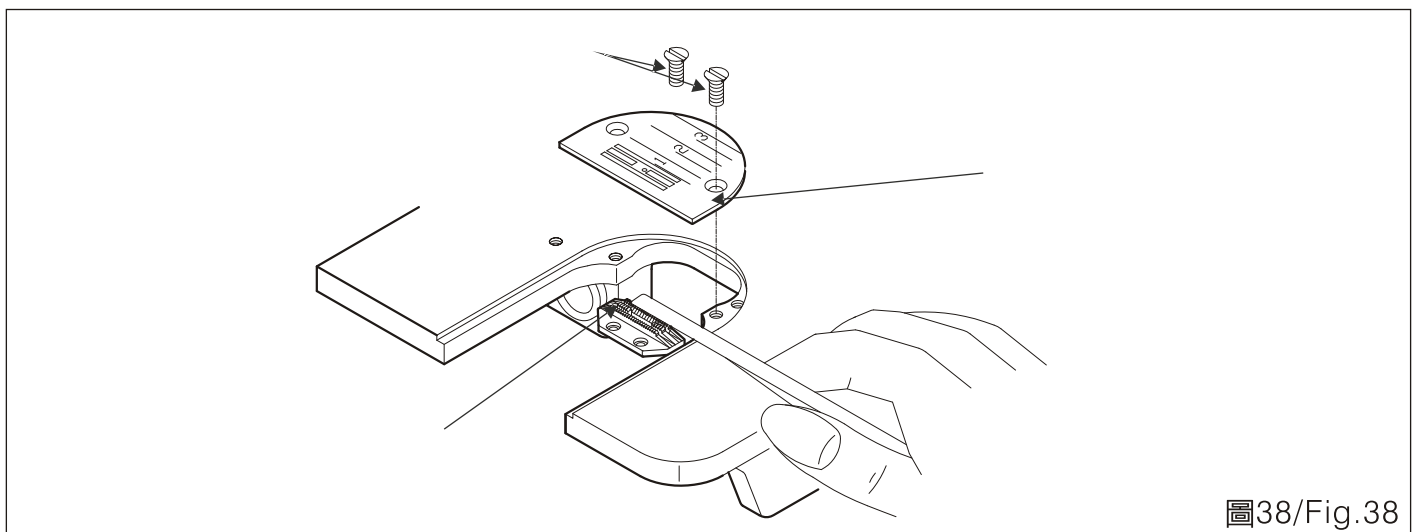
- (1) 由調整栓①調整針棒曲柄② / 挑線桿③之供油量。
- (2) 將調整栓①順著 B 方向調整，使 A 點靠近針棒曲柄②，則供油量減少。
- (3) 將調整栓順著 C 方向調整，使 A 點離開針棒曲柄②，則供油量增加。

## 1. Oil lubrication instruction (Fig.39)

- (1) Fill the oil pan with specified oil up to high mark A.
- (2) If the oil level is lower than the low mark B, refill the oil pan with the specified oil.
- (3) You will see oil splashing via oil sight window ② if the lubrication functions is well when machine runs.
- (4) When running the machine at first time or after a period of time, please run your machine at 3000 to 3500 SPM for about 10 minutes.

## 2. Oil supply adjustment for needle bar/thread take-up lever (Fig. 40)

- (1) Turning adjust pin ① to adjust the supplied oil volume to the needle bar crank ② and the thread take-up ③.
- (2) To decrease supplied oil amount, turn the adjust pin ① in direction B to make the mark A close to the needle bar crank ②.
- (3) To increase the supplied oil amount, Turn the adjust pin ① in direction C to make the mark A away from the needle bar crank ②.



圖39/Fig.39

## 3. 梭頭油量 (噴油量) 之調整

- (1) 油量確認試紙。約 25mm × 70mm，可使用任何材質之試紙。(圖 40)

## 3. Adjust the oil amount of the hook (oiling Amount).

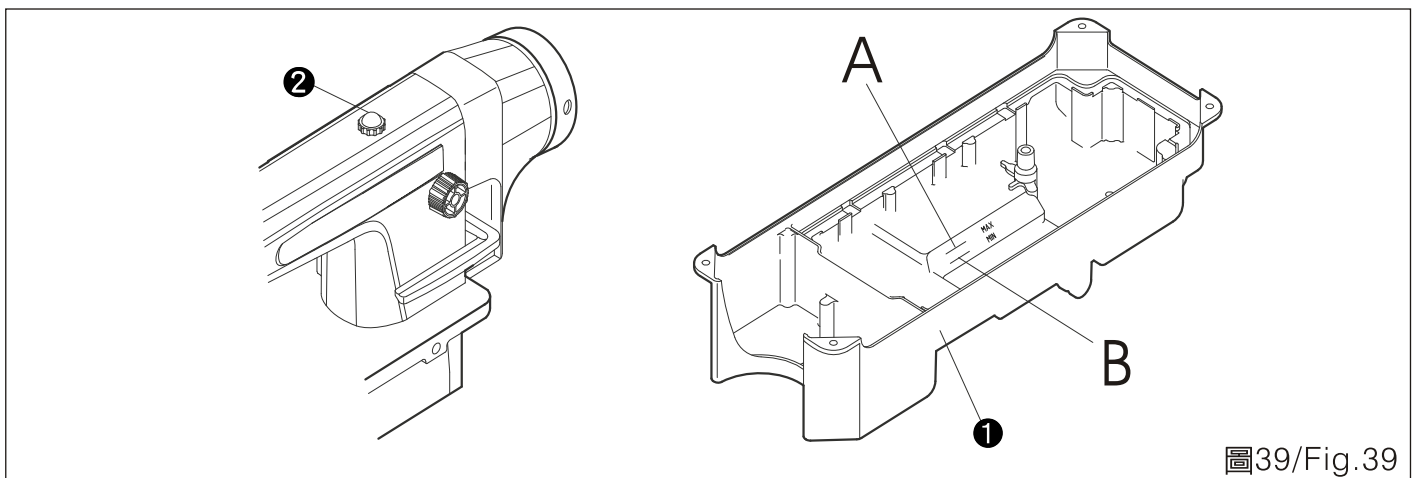
- (1) Oil splashing test paper is about 25mm × 70mm. Any material of test paper is accepted. The material will not affect results. (Fig. 40)

- (2) 確認油量位置。將試紙靠緊油盤壁，將油量確認試紙置於梭頭下方。  
 (圖 45)  
 ①梭頭 ②紙 ③油盤  
 ④梭觸點 ⑤底座 ⑥襯套

當進行第 (2) 步驟時，移開滑板並非常小心，勿使手指觸及梭頭。

4. 注意事項：

- (1) 如機器尚未充分熱機，請先將機器空轉 3 分鐘暖車。  
 (2) 在機器運轉中，將油量確認試紙置於梭頭下方。(圖 41)  
 (3) 確認油盤油量 (油面) 介於「高」與「低」刻度間。  
 (4) 必須在 5 秒鐘內完成確認油量之動作 (用手錶測時間)。

- (2) Confirm the oil amount. Place the test paper under the hook and fit the paper closely against to the wall of the oil pan. (Fig. 45)

- ① HOOK ② PAPER ③ OIL PAN  
 ④ TOUCHING ⑤ BASE ⑥ BUSHING

When doing step (2), carefully remove the sliding plate and do not touch the hook with fingers.

4. Attentions:

- (1) If the machine doesn't warm up enough, please run the machine 3 minutes idly.  
 (2) While the machine is running, place the oil splashing test paper under the hook. (Fig. 41)  
 (3) Confirm that the height of the oil level in the oil pan falls between "HI" and "LOW".  
 (4) Oil splashing observation test should be completed in 5 seconds. (Use a watch to check the time used.)



圖40/Fig.40



圖41/Fig.41

5. 適當油量顯示範例 (圖 42)  
梭頭噴油量約 1mm 適當油量 (小)

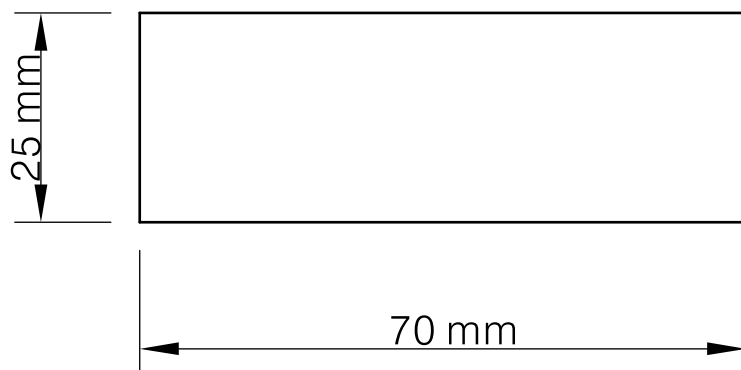
DL918-H: 3mm  
DL918-M: 1.5mm

梭頭噴油量約 2mm 適當油量 (大)

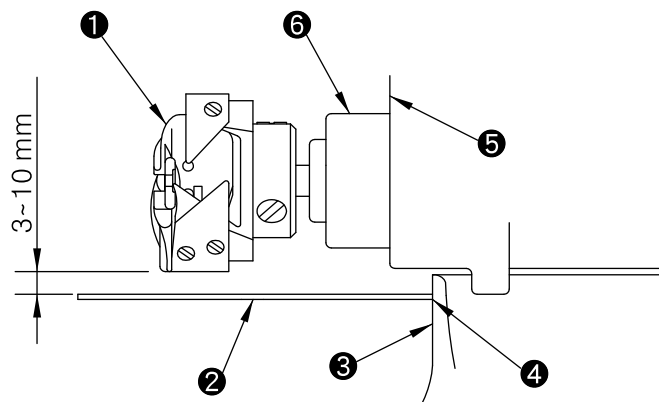
DL918-H: 6mm  
DL918-M: 3mm

(1) 油量顯示範例必須根據車縫布料與程序加以調整，切勿使梭頭油量過多或過少。油量過少，梭頭將卡住 (梭頭將發熱)；油量過多，車縫物將可能沾染油污。

(2) 調整梭頭油量，油量必須達到 3 次測試都相同 (在 3 張試紙上)。

5. A sample of observations indicate the appropriate oil amount. (Fig. 42)  
Oil amount in the hook (small) as shown is approximated 1mm.

DL918-H: 3mm  
DL918-M: 1.5mm

OIL amount in the hook (large) as shown is approximated 2mm

DL918-H: 6mm  
DL918-M: 3mm

(1) The amount of oil in the hook (ref. to the sample shown on Fig. 9) should be Adequately adjusted according to the sewing materials and processed. Insufficient amount of oil will cause the hook to cease and overheat. Excess amount of oil may cause the sewing product stained with oil.

(2) Adequate adjustment should be reached in the way that same oil splashing observation will be collected in 3 ties on separate paper.

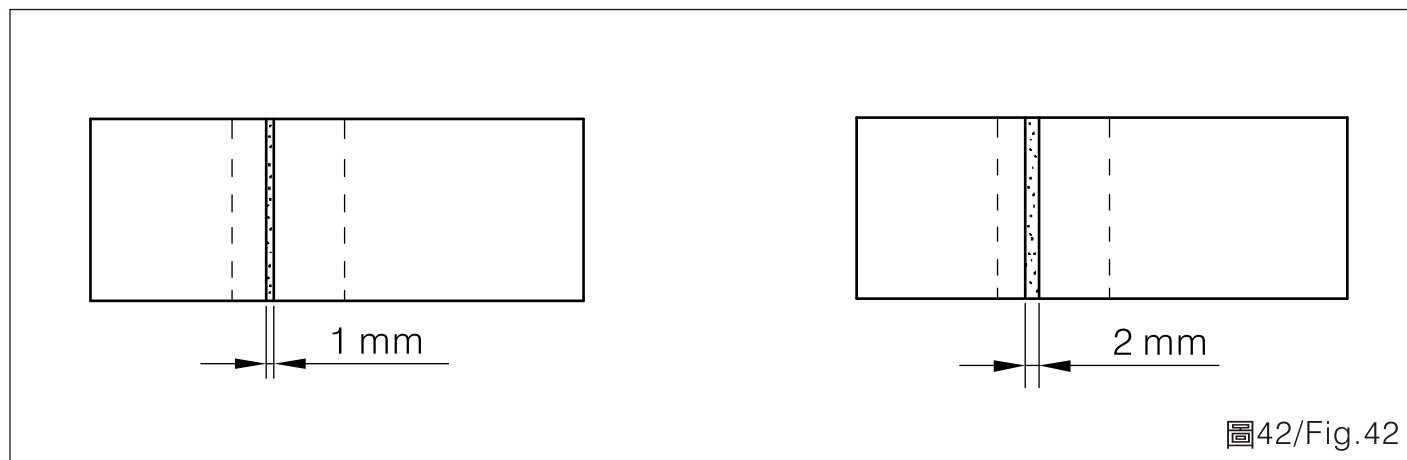

### 動刀與固定刀的更換

### REPLACING THE MOVABLE KNIFE AND FIXED KNIFE

調整時注意事項：

1. 更換零件時，為避免縫紉機動作傷人，請切斷電源。
2. 請使用 SIRUBA 公司指定更換零件。

Adjustment note:

1. Turn off the power to avoid the operation Accident when replacing parts.
2. Please use designated parts by SIRUBA.

### 1. 固定刀更換 (圖 43)

- (1) 將縫紉機頭向後傾斜。
- (2) 旋出螺絲①，取出旋梭定位器②。
- (3) 旋出螺絲③，取出定刀④。
- (4) 安裝順序與拆卸時步驟相反。

### 2. 固定刀刀刃的研磨方法 (圖 44)

如果固定刀的刃部受損或磨損，請將固定刀④如圖所示在油磨石⑤上研磨固定刀。



圖43/Fig.43

### 3. 更換動刀 (圖 45)

- (1) 取下機針，抬起壓腳。
- (2) 旋出螺絲①，取出針板②。
- (3) 將縫紉機頭部向後傾斜。
- (4) 回轉手輪使針桿位置升至最高。
- (5) 將切線連桿③用手撥向箭頭方向，直至看到動刀螺絲④的位置。
- (6) 旋下兩顆螺絲，然後取出動刀⑤。
- (7) 安裝順序與拆卸時步驟相反。

### 1. Replace the fixed knife (Fig.43)

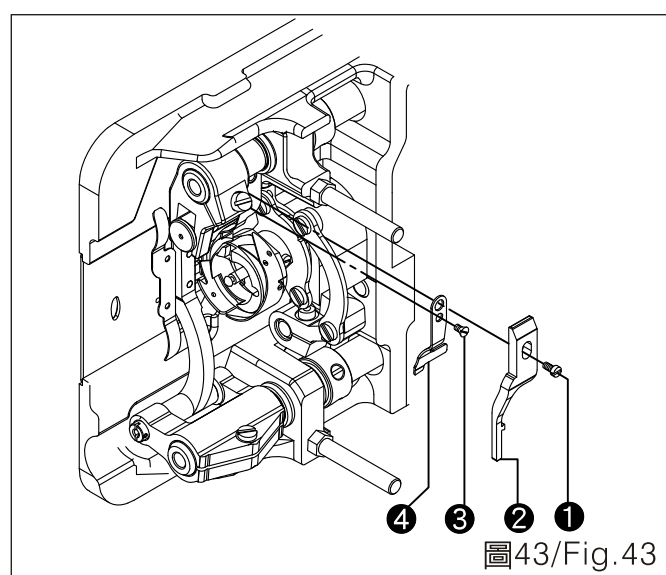
- (1) Tilt the sewing machine head backward.
- (2) Loosen the screw ① and remove the hook locator ② .
- (3) Loosen the screw ③ and remove the fixed knife ④ .
- (4) The installing procedure is opposite to the removing procedure.

### 2. Sharpening the fixed knife blade (Fig.44)

If the fixed knife blade is worn out, please sharpen the fixed knife ④ on the oilstone ⑤ as figure shows.



圖44/Fig.44

### 3. Replacing the movable knife (Fig.45)

- (1) Remove the needle and lift the presser foot.
- (2) Loosen the screw ① and remove the needle plate ② .
- (3) Tilt the sewing machine head backward.
- (4) Turn the hand wheel to make the needle lever lift to the highest position.
- (5) Wipe the thread trimmer connecting rod ③ to the arrow pointed direction until the movable screw ④ can be seen.
- (6) Loosen two screws and remove the movable knife ⑤ .
- (7) The installing procedure is opposite to the removing procedure.

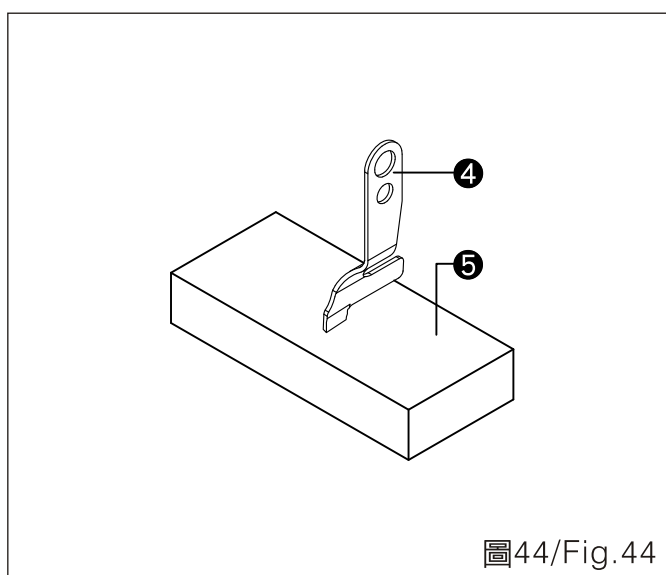

圖45/Fig.45





1. 當機器需要被淘汰與報廢時，有一些基本規則必須採納、遵守以保護環境及公眾健康。
  2. 所有的機器零件必須依照下列分類來區分開：
    - (1) 所有護套、可伸縮軟管及塑膠或非金屬零件。
    - (2) 電器零件：開關、照明器具等。
    - (3) 絕緣材料：石棉、彈性 / 可伸縮橡膠片。
    - (4) 金屬：含鐵金屬、銅、青銅與黃銅、其他各種金屬。
  3. 以此方法，所有材質可以正確的淘汰，回收再利用或熔解為可再使用或再處理而不至於危害環境。
1. When the machine needs to be eliminated and demolished, certain basic rules must be observed to protect the environment and public health.
  2. ALL machine components must be divided according to categories as the followings:
    - (1) All sheathes, flexible hosing and plastic or non-metal components.
    - (2) Electricity components: switches, or lighting components.
    - (3) Insulation materials: rock wool, and Flexible rubber strips.
    - (4) Metals: ferrous metals, copper, bronze and brass, various.
  3. In this way, all materials can be eliminated correctly, recycled, or melted down for reuse or disposed of so that they do not harm the environment.

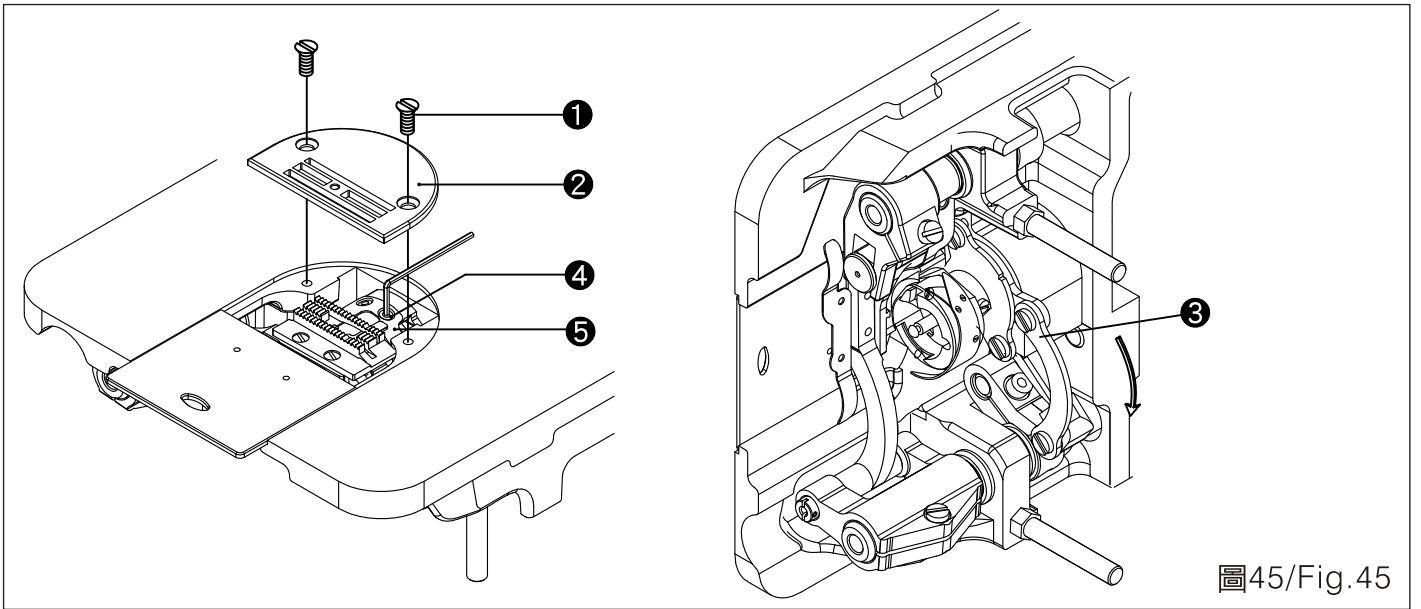

# DL918-BM1/BH1

高林股份有限公司 KAULIN MFG. CO., LTD.